

**INDICE
ALTERNADORES
PAGINAS 01 a 36**

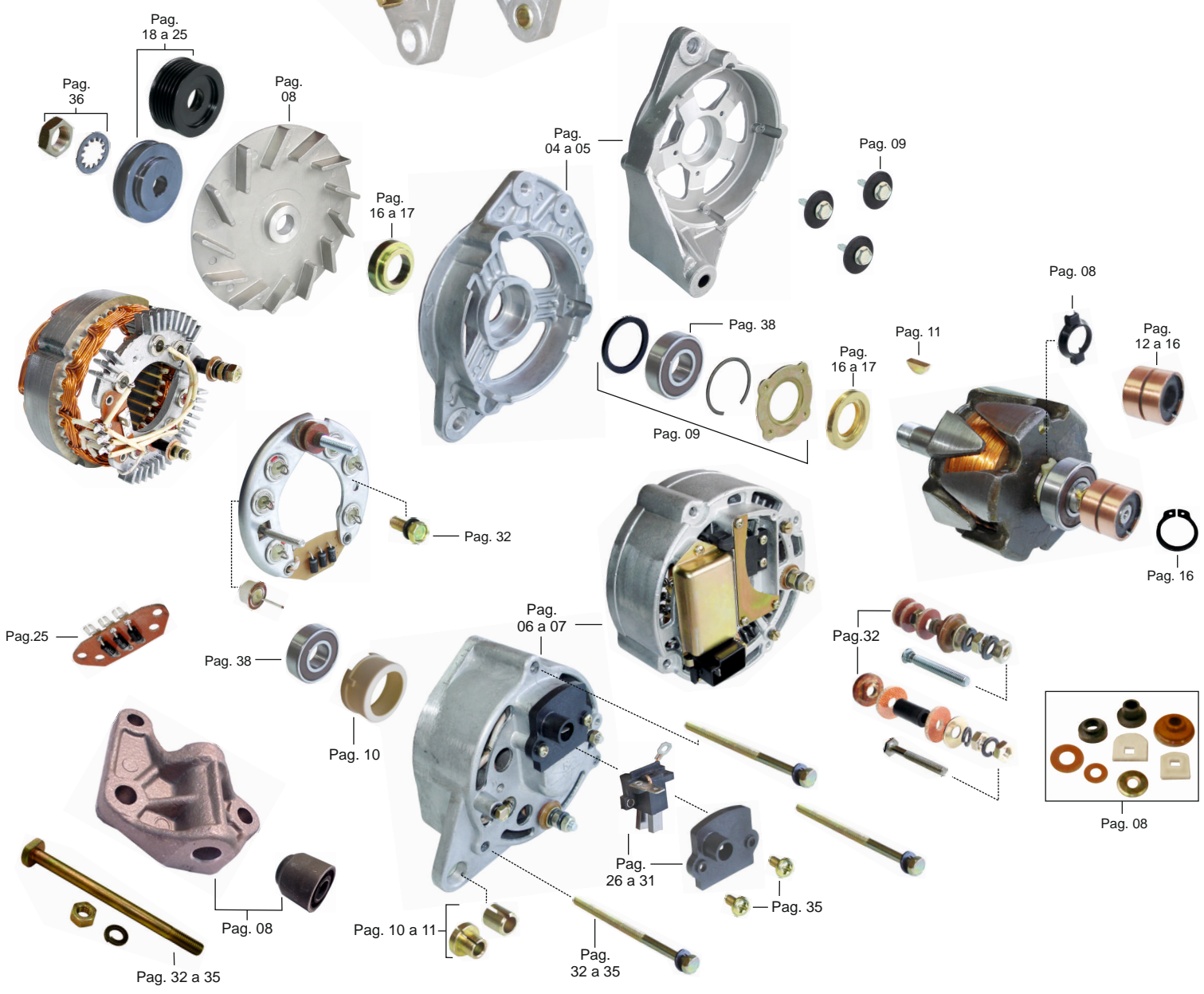

**DINAMO
PAGINAS 37 a 38**



INDICE
LIMPIAPARABRISAS
PAGINAS 39 a 75

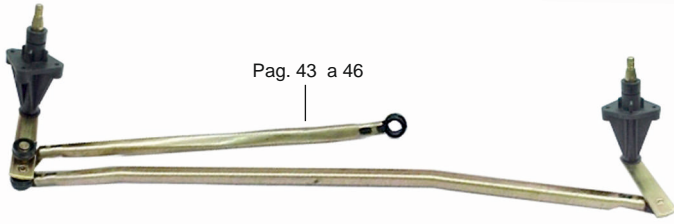

Pag. 43 a 46

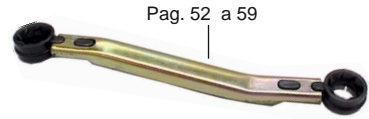

Pag. 52 a 59



Pag. 16 a 19



Pag. 50



Pag. 50 a 51

Pag. 43



Pag. 61 a 62



Pag. 52

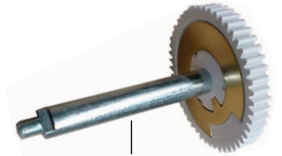

Pag. 63 a 71

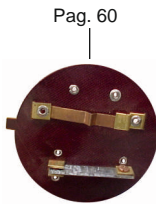

Pag. 60



Pag. 60 a 61

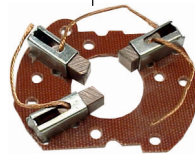

Pag. 62

ELECTROVENTILADOR
PAGINAS 39 a 40

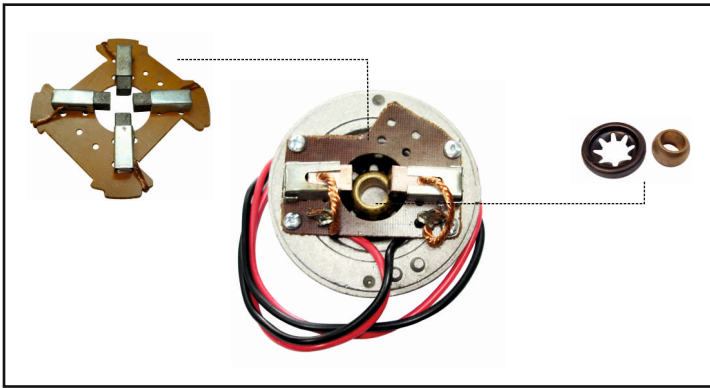

CALEFACTOR
PAGINAS 41

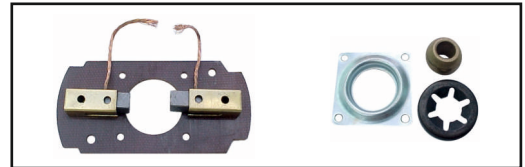

MOTOR DE ALTA Y BAJA
PAGINA 43

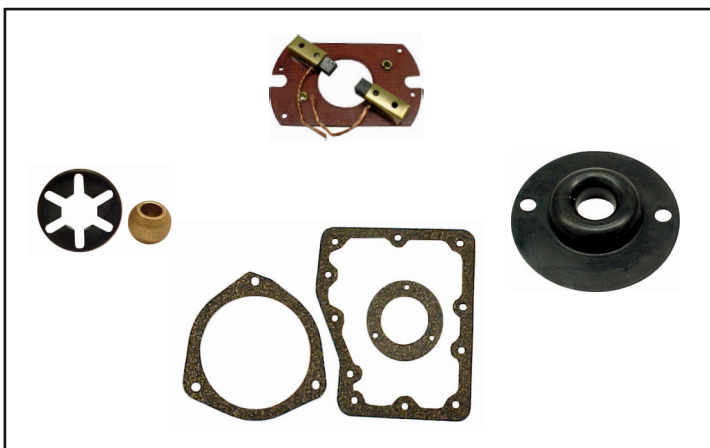

VARIOS
PAGINAS 71 a 75



ALTERNADORES

M. BENZ



313285R
T. BOSCH M. BENZ 24V. 140A
C/REGULADOR Y POLEA



312198RM
24V. 100A. TIPO BOSCH
ESPAÑOL, M. BENZ
C/REGULADOR Y POLEA
MULTIVIA (RUL. 62304)

312198R
24V. 100A. TIPO
BOSCH, MERCEDEZ
BENZ C/REGULADOR
(RUL. 62304)

M. BENZ



311160R
12V. 100A. M. BENZ
C/REGULADOR Y POLEA

312161R
24V. 90A. M. BENZ
C/REGULADOR Y POLEA



311100A
12V. 70A M. BENZ CON POLEA

312100A
24V. 60A. M. BENZ C/POLEA

M. BENZ



311280
12V. 70A. M. BENZ S/POLEA

312285
24V. 60A. M. BENZ S/POLEA

311280A
12V. 70A. M. BENZ C/POLEA

312285A
24V. 60A. M. BENZ C/POLEA

311280R
12V. 70A. M. BENZ
C/REGULADOR

312285R
24V. 60A. M. BENZ
C/REGULADOR Y POLEA



311198R
12V. 100A TIPO BOSCH,
M. BENZ C/REGULADOR
(RUL. 62304)

ALTERNADORES

UNIVERSAL
TIPO INDIEL 55A.

311130
12V. 55A. UNIVERSAL
FALCON AMPERIMETRO

311130A
12V. 55A. UNIVERSAL
FALCON C/LUZ PILOTO

311130R
12V. 55A. UNIVERSAL CHICO C/REGULADOR
FALCON, PEUGEOT, FIAT, ETC.

311130RT
12V. 55A. UNIVERSAL CHICO C/REGULADOR
Y TACOMETRO, FALCON, PEUGEOT, FIAT, ETC.

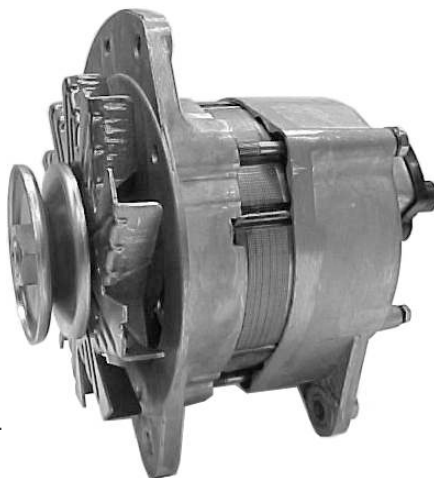

312135
24V. 50A. UNIVERSAL CHICO

312135R
24V. 50A. UNIVERSAL CHICO
C/REGULADOR

312135RT
224V. 50A. CHICO C/REGULADOR
Y TACOMETRO

UNIVERSAL
TIPO INDIEL 70A.

311120
12V. 70A. UNIVERSAL (RUL.6203)

311120R
12V. 70A. C/REGULADOR INCORPORADO

311121R
12V. 70A. PERKINS (RUL.6205) REG.INC.

311122
12V. 70A. UNIVERSAL (RUL.6205)

311122R
12V. 70A. UNIVERSAL (RUL.6205) REGULADOR INC

311134R
12V. 70A. DEUTZ C/REGULADOR Y POLEA

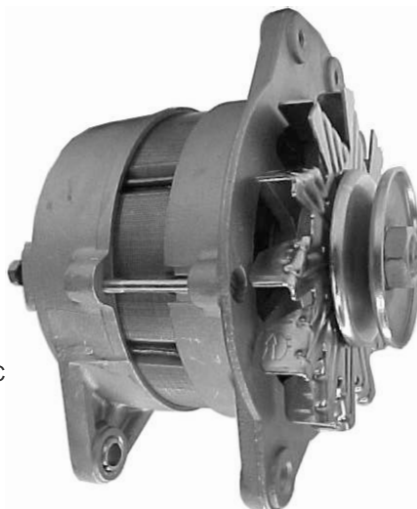

311169R
12V. 70A. PEUGEOT C/REGULADOR

312120R
24V. 60A. UNIVERSAL C/REGULADOR

312122
24V. 60A. UNIVERSAL (RUL.6205)

312122R
24V. 60A. (RUL.6205) C/REGULADOR

312123R
24V. 60A. FIAT C/REGULADOR

312134R
24V. 60A. DEUTZ C/REGULADOR Y POLEA

UNIVERSAL
TIPO NASHVILLE



311252R
12V. 70A. DEUTZ
C/REGULADOR Y POLEA

312254R
24V. 60A. FIAT 150 TIPO
C/REGULADOR Y POLEA

312255R
24V. 60A. UNIVERSAL
C/REGULADOR

SCANIA



312270R
24V. 60A. SCANIA C/REGULADOR Y POLEA

ALTERNADORES

SCANIA





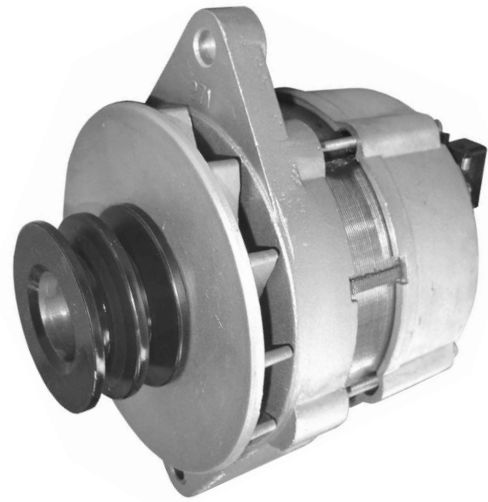





















313284R
24V. 150A. TIPO BOSCH, SCANIA C/REGULADOR



312171R
24V. 90A. SCANIA C/REGULADOR Y POLEA

TAPA DELANTERA ALTERNADOR

 <p>401009 TIPO INDIEL UNIVERSAL PERKINS, DODGE, DEUTZ, FIAT, ETC. 55A. RULEMAN 6203</p>	 <p>401009/1 TIPO INDIEL UNIVERSAL PERKINS, DODGE, DEUTZ, FIAT, ETC. 70A. RULEMAN 6203</p>	 <p>401009/2 TIPO INDIEL PERKINS INDIEL 35211369 RULEMAN 6205</p>	 <p>401011 SCANIA/DEUTZ TIPO NASHVILLE 125A.</p>
 <p>401011/1 TIPO NASHVILLE 125A. PATA CORTA</p>	 <p>401011/2 TAPA DELANTERA DE ALERNADOR TIPO NASHVILLE, SCANIA 125A.</p>	 <p>401014 TIPO INDIEL AVI128 R19 1.8 EXPRESS DIESEL 35214223</p>	 <p>401014/1 TIPO INDIEL AVI128 R19 1.8 EXPRESS DIESEL C/BUJE 35214223</p>
 <p>401015 TIPO INDIEL AVI128, GOL PARATI GIII (ANT. 35214403) K01156</p>	 <p>401036 M. BENZ TIPO INDIEL 55A.</p>	 <p>401036/1 M. BENZ TIPO INDIEL 70A.</p>	 <p>401101 UNIVERSAL TIPO NASHVILLE RULEMAN 6203</p>
 <p>401101/1 DEUTZ UNIVERSAL TIPO NASHVILLE RULEMAN 6303</p>	 <p>401102 M. BENZ, TAUNUS TIPO INDIEL 90A.</p>	 <p>401103 RENAULT TIPO ARGELITE CHICO</p>	 <p>401109 M. BENZ TIPO NASHVILLE</p>
 <p>401181 TIPO PRESTOLITE (PORTARULEMAN ALE 3)</p>	 <p>401201 FIAT 128/125 TIPO GAREF (5116875)</p>	 <p>401202 DUNA/UNO/FIORINO TIPO GAREF</p>	 <p>401203 TIPO NASVILLE FIAT 150 TURBO</p>
<p>AGUJERO CON ROSCA</p>  <p>401210 TIPO M. MARELLI FORD, TRANSIT, ROVER, ETC.</p>	<p>AGUJERO CON ROSCA</p>  <p>401211 TIPO M. MARELLI, FORD FIESTA</p>	 <p>401220 TIPO BOSCH M. BENZ SPRINTER</p>	 <p>401222 TIPO BOSCH C/DEPRESOR CHEVROLET</p>

TAPA DELANTERA ALTERNADOR



401230
TIPO M. MARELLI/
NIPPONNIPPONDENSO FORD
FIESTA/ESCORT/COURRIER



401270
SCANIA TIPO NASHVILLE 70A.



401271
SCANIA TIPO INDIEL 100A.



401272
M. BENZ 90A. TIPO INDIEL
RULEMAN 6303



401273
M. BENZ TIPO NASHVILLE 100A.



401274
UNIVERSAL TIPO
NASHVILLE 100A.



401276
TIPO INDIEL FIAT REGATTA 100
35213420



401278
TIPO INDIEL PEUGEOT 505
C/AIRE ACONDICIONADO
35213707



401280
TAPA DELANTERA DE
ALERNADOR TIPO BOSCH 75A.



401281
TIPO BOSCH 105/125A.



401283
CUMMINS 75A. TIPO BOSCH



401284
FORD PICK UP TIPO WAPSA



401285
TIPO BOSCH 105/140A.

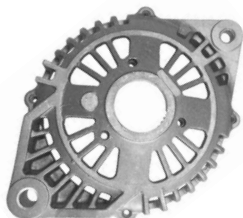

401014
TIPO INDIEL AVI128 R19 1.8
EXPRESS DIESEL 35214223



401294
TIPO BOSCH 24V. 24/55A.



401295
TIPO BOSCH 12V 55A.



401296
TIPO BOSCH, SCANIA



401297
TIPO BOSCH M. BENZ 90-100A.



401298
TIPO BOSCH ESPAÑOL M. BENZ
100 1.125.825.365



401303
FORD UNIVERSAL TIPO
INDIEL 38A.



401304
RENAULT 9/19 TIPO M. MARELLI



401403
TIPO GAREF, FALCON, PEUGEOT

TAPA TRASERA ALTERNADOR



451004
FORD TIPO INDIEL 38A.

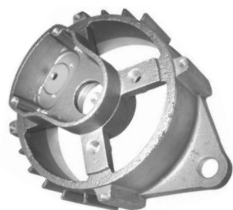

451012
SCANIA, DEUTZ TIPO NASHVILLE
125A. A/A



451012/1
TIPO NASHVILLE 125A. P/PATA
CORTA



451012/2
TIPO NASHVILLE SCANIA 125A.



451013
M. BENZ TIPO INDIEL 55A.



451013/1
M. BENZ TIPO INDIEL 70A.

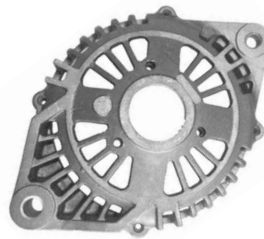

451014
TIPO TIPO INDIEL AVI128 RENAULT
35214593/35214239

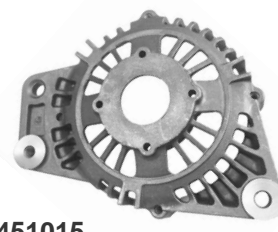

451015
TIPO TIPO INDIEL AVI128, GOL
PARATI GIII (COD.ANTERIOR
35214403) K01156



451032
M. BENZ, TIPO NASHVILLE



451032/1
M. BENZ TIPO NASHVILLE
P/REGULADOR INCORPORADO



451044
PERKINS TIPO INDIEL 55A.



451044/1
PERKINS TIPO INDIEL 70A.



451102
UNIVERSAL TIPO NASHVILLE



451102/1
DEUTZ UNIVERSAL TIPO
NASHVILLE REGULADOR
INCORPORADO



451103
M. BENZ SIERRA TIPO INDIEL 90A.



451104
TIPO NASVILLE FIAT 150



451180
TIPO PRESTOLITE



451180R
UNIVERSAL TIPO ARGELITE
C/LUZ PILOTO



451301
F.128/125 TIPO GAREF



451302
DUNA, UNO, FIORINO,
TIPO GAREF



451303
TIPO GAREF F. FALCON,
PEUGEOT



451320
TIPO BOSCH C/DEPRESOR M.
BENZ SPRINTER (F000 LD1 412)

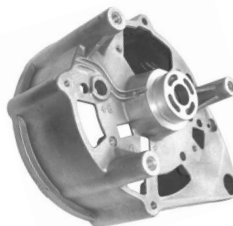

451321
TIPO BOSCH C/DEPRESOR
CHEVROLET



451322
TIPO BOSCH C/DEPRESOR
CHEVROLET SILVERADO
MOTOR MWM

TAPA TRASERA ALTERNADOR



451330
TIPO NIPPONDENSO/
M. MARELLI FORD FIESTA/
ESCORT/COURRIER



451373
M. BENZ TIPO TIPO NASHVILLE
100A.



451374
UNIVERSAL TIPO TIPO
NASHVILLE 100A.



451380
TIPO TIPO BOSCH 75A.



451380R
REFORMA DIPRA C/SOPORTE
TIPO BOSCH RULEMAN
63003/6003



451381
TIPO BOSCH 105/125A.



451382
TIPO BOSCH 75A. REFORMA
DIPRA RULEMAN 63003/6003



451385
105/140A. SCANIA TIPO BOSCH
(PATA LARGA)



451386
TIPO BOSCH 105/125A. M. BENZ
(PATA LARGA)



451390
TIPO INDIEL M. BENZ, SCANIA,
F.CARGO (35213562)



451390/1
M. BENZ, SCANIA, F.CARGO
Ø128.4

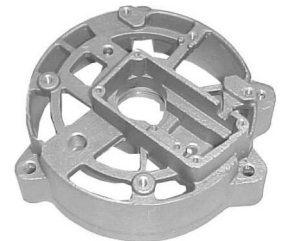

451391
TIPO INDIEL RENAULT 18 C/AIRE
(35213060)

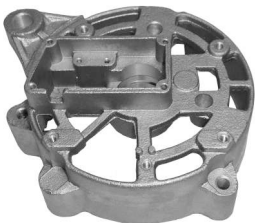

451392
FORD SIERRA/ESCORT



451393
GACEL TIPO INDIEL



451394
TIPO BOSCH BRASIL 24V.
35/55A. M. BENZ



451395
TIPO BOSCH 12V. 55A. M. BENZ



451396
TIPO BOSCH SCANIA



451397
TIPO BOSCH M. BENZ 90/100A.



451398
TIPO BOSCH ESPAÑOL 90/100A.
1.125.885.270



451402
RENAULT TIPO ARGELITE CHICO

TURBINAS

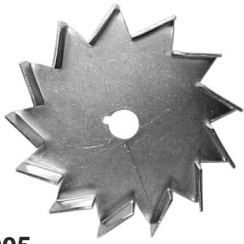

V1005
TIPO NASHVILLE BAJA 55/70A.
EJE 17MM.



V1006
TIPO INDIEL 90/100A. EJE 17MM.

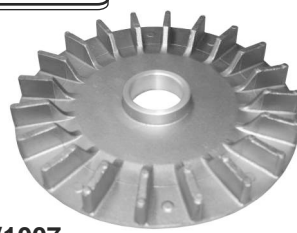

V1007
TIPO BOSCH, WAPSA 24V. 75A.
M. BENZ EJE 30MM.



V1008
TIPO BOSCH, WAPSA 125/140A.
EJE 30MM.



V1009
TIPO INDIEL, GAREF UNIVERSAL
EJE 17MM.



V1010
TIPO BOSCH, M. BENZ, FIAT,
SCANIA EJE 17MM.



V1011
TIPO BOSCH, M. BENZ, FIAT,
SCANIA EJE 17MM.

SOPORTES ALTERNADOR



RM3008
SOPORTE ALTERNADOR FIAT 619



B2006
BUJE SOPORTE M. BENZ
MODELO VIEJO LARGO 22.5MM.



B2008
BUJE SOPORTE M. BENZ DE
TEFLON



B2009
BUJE SOPORTE M. BENZ OH,
ETC. MODELO NUEVO LARGO
25.5MM.

AISLACIONES Y BUJES



A7001
AISLACIONES DE NYLON SURTIDAS
(CANT. 40)



A7007
AISLANTES SALIDA ROTOR
1 SALIDA ALTO (CANT. 5)



A7008
AISLANTES SALIDA ROTOR
2 SALIDAS (CANT. 5)



A7009
AISLANTES PLASTICO DE ROTOR
(CANT. 5)



A7013
CONJUNTO DE BUJES AISLANTES
ALTERNADOR TIPO NASHVILLE



A7014
JUEGO AISLACIONES
ALTERNADOR TIPO
BOSCH 24V.75A.



A7018
JUEGO AISLACIONES
ALTERNADOR TIPO ARGELITE



A7025
REPARACION ALTERNADOR
TIPO NASHVILLE (010 021)

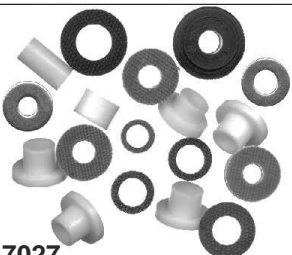

A7027
JUEGO AISLACIONES
ALTERNADOR TIPO INDIEL

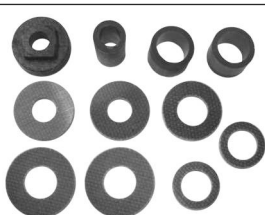











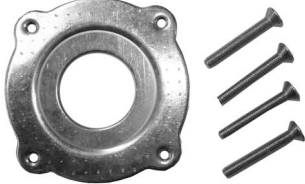

A7028
JUEGO AISLACIONES
ALTERNADOR TIPO INDIEL
90/100A.

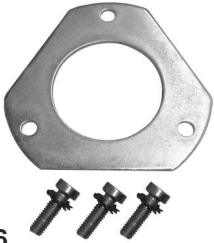

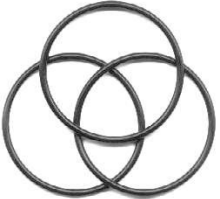
A7037
JUEGO AISLACIONES
ALTERNADOR TIPO GAREF

SEGUROS Y RETENES

 <p>A1038 RETEN SUJETA RULEMAN ESPECIAL</p>	 <p>A6008 SUJETA RULEMAN ALTERNADOR TIPO BOSCH 75/125A.</p>	 <p>A6009 RETEN ALTERNADOR TIPO BOSCH 24V.75A.</p>	 <p>A6010 RETEN SUJETA RULEMAN ALTERNADOR TIPO BOSCH 10-100A.</p>
 <p>A6011 ARADELA RETEN TIPO BOSCH 140A.</p>	 <p>A6017 ARO DE ACERO DE RULEMAN</p>	 <p>A6017G ARO DE ACERO DE RULEMAN 6303</p>	 <p>A6040 CHAPA RETEN RULEMAN ALTERNADOR 55A.</p>
 <p>A6046 ARADELA RETEN RULEMAN ALTERNADOR TIPO INDIEL 100A.</p>	 <p>A6047 TORNILLOS SUJETA RULEMAN ALTERNADOR 90/100A.</p>	 <p>A6062 ARADELA RETEN RULEMAN ALTERNADOR TIPO NASHVILLE</p>	
RETENES DE GOMA			
 <p>G1517 ANILLOS ELASTICOS TAPA TRASERA ALTERNADOR TIPO GAREF (CANT. 3)</p>	 <p>G1518 ALTERNADOR TIPO INDIEL / NASHVILLE RULEMAN 6202 (CANT. 5)</p>	 <p>G1519 TOPE RULEMAN 6203 ALTERNADOR TIPO TIPO INDIEL / GAREF (CANT. 1)</p>	 <p>G1521 TOPE RULEMAN 6303 ALTERNADOR TIPO TIPO INDIEL (CANT. 1)</p>

BUJES DE PLASTICO PARA RULEMAN

 <p>B3001 RULEMAN 6201 ALTERNADOR TIPO VALEO 32X34.1X15.6MM.</p>	 <p>B3002 RULEMAN 6202/6003 ALTERNADOR TIPO M. MARELLI FORD 4 GUIAS 35.15X37X14.7MM.</p>	 <p>B3003 RULEMAN 6202/6003 ALTERNADOR TIPO M. MARELLI 3 GUIAS 35.15X37X14.7MM.</p>	 <p>B3004 RULEMAN 6201 ALTERNADOR TIPO BOSCH 1.120.581.082 31.95X34.95X18.35MM.</p>
 <p>B3005 RULEMAN 6202 ALTERNADOR TIPO VALEO PARA 34.94X37.7X19.5MM.</p>	 <p>B3006 RULEMAN 6202 ALTERNADOR TIPO M. MARELLI 34.95X36.96X18MM.</p>	 <p>B3007 RULEMAN 6000 ALTERNADOR TIPO VALEO/PARIS RHONE 29.6X32X13.30MM.</p>	 <p>B3008 RULEMAN 6000 ALTERNADOR TIPO DELCO REMY 26.06X28X11.4MM.</p>
 <p>B3009 RULEMAN 6201 ALTERNADOR TIPO VALEO 31.84X33.93X16.30MM.</p>	 <p>B3010 RULEMAN 6201 ALTERNADOR TIPO VALEO 31.84X33.93X17.30MM.</p>	 <p>B3011 RULULEMAN 62201 ALTERNADOR TIPO BOSCH 32X37X14.7MM.</p>	 <p>B3012 RULEMAN 6203 ALTERNADOR TIPO BOSCH 39.8X42.6X17MM.</p>
 <p>B3014 RULEMAN 6201 ALTERNADOR TIPO PARIS RHONE 29.7X32.02X11.77MM.</p>	 <p>B3015 RULEMAN 6201 ALTERNADOR TIPO PARIS RHONE 32X34.6X13.80MM.</p>	 <p>B3016 RULEMAN 6202 ALTERNADOR TIPO BOSCH 5G</p>	 <p>B3017 RULEMAN 6203 ALTERNADOR TIPO BOSCH 5G</p>
 <p>B3018 ALTERNADOR TIPO BOSCH GOL TREND, KANGOO, FOX, SURAN</p>	<p>BUJES PARTIDOS</p>		
 <p>B1010 ALTERNADOR TIPO NASHVILLE 12.75X18X32MM. CON PESTAÑA 24.5X5MM.</p>	 <p>B1011 ALTERNADOR TIPO NASHVILLE 18X12.25X32MM.</p>	 <p>B1012 ALTERNADOR TIPO GAREF 10X12.3X13MM C/PESTAÑA CHICO</p>	 <p>B1013 ALTERNADOR TIPO GAREF 10X15X18MM. C/PESTAÑA GRANDE</p>

BUJES PARTIDOS



B1014
ALTERNADOR TIPO NASHVILLE
12.25X17.8X25MM. FIAT 150



B1016
ALTERNADOR TIPO M. MARELLI
8.4X13.5X25MM. C/PESTAÑA



B1017
ALTERNADOR TIPO M. MARELLI
8.4X13.5X20MM.



B1018
ALTERNADOR TIPO BOSCH /
M. MARELLI 12.4X21MM.



B1026
ALTERNADOR TIPO GAREF
10X15X22.7MM.



B1028
ALTERNADOR TIPO INDIEL /
NASVILLE / GAREF / ETC.
10X15X17MM.



B1035
ALTERNADOR TIPO GAREF /
INDIEL 15X10X28MM. PEUGEOT



B1036
ALTERNADOR TIPO M. MARELLI,
FORD



B1037
ALTERNADOR 140A.TIPO
BOSCH SCANIA



B1038
ALTERNADOR TIPO BOSCH
140A. 11X14X8MM. C/ PESTAÑA
21X2MM.



B1039
ALTERNADOR 9X16X32MM.
C/ PESTAÑA 24X2.5MM.



B1062
ALTERNADOR TIPO VALEO
10.5X16X21MM. C/ PESTAÑA
24X2MM.

CHAVETAS

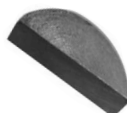

C2010
1/2 LUNA ALTERNADOR TIPO
NASHVILLE 55/70A. (CANT. 1)

C2011
IDEM (CANT. 10)

C2065
IDEM (CANT. 20)



C2012
ALTERNADOR TIPO NASHVILLE
125A. (CANT. 1)



C2060
MEDIA LUNA SURTIDAS (CANT. 50)

C2068
IDEM (CANT. 25)



C2061
PARTIDAS SURTIDAS (CANT. 100)



C2063
MEDIA LUNA ALTERNADOR TIPO
BOSCH/WAPSA 125/140A. (CANT. 1)

C2064
IDEM (CANT. 10)



C2069
MEDIA LUNA ALTERNADOR TIPO
BOCH / WAPSA 24V, 75A. 5X7,5MM
(CANT. 10)

C2070
AIDEM (CANT. 1)



C2071
MEDIA LUNA ALTERNADOR TIPO
BOSCH 28/55/70A. (CANT. 1)

C2072
IDEM (CANT. 10)

COLECTORES

COLECTORES

 <p>C4033 TIPO DELCO REMY A: 8 - B: 15 - C: 20</p>	 <p>C4034 TIPO BOSCH A: 5.25 - B: 13.5 - C: 46.7</p>	 <p>C4035 TIPO MOTORCRAFT A: 5 - B: 14.35 - C: 20.8</p>	 <p>C4036 TIPO INDIEL CON DEPRESOR A: 14.3 - B: 25.4 - C: 18.5</p>
 <p>C4038 TIPO MOTORCRAFT A: 5 - B: 15.5 - C: 18</p>	 <p>C4039 TIPO GAREF / BOSCH A: 17 - B: 32.8 - C: 22.5</p>	 <p>C4040 TIPO MOTORCRAFT A: 13.5 - B: 27 - C: 37</p>	 <p>C4041 TIPO MOTORCRAFT A: 13.5 - B: 27 - C: 35</p>
 <p>C4042 TIPO MITSUBISHI A: 13.4 - B: 23.5 - C: 30</p>	 <p>C4045 TIPO GILERA / NASHVILLE A: 15 - B: 30 - C: 17</p>	 <p>C4049 TIPO NASHVILLE A: 17.5 - B: 38 - C: 24.4</p>	 <p>C4051 TIPO BOSCH A: 14.2 - B: 30 - C: 24.5</p>
 <p>C4052 TIPO MITSUBISHI CON DEPRESOR A: 17.5 - B: 33.5 - C: 31</p>	 <p>C4053 TIPO ISUZU / TOYOTA A: 17 - B: 34.5 - C: 28</p>	 <p>C4054 TIPO MITSUBISHI A: 13.5 - B: 23.5 - C: 29</p>	 <p>C4055 TIPO DELCO REMY A: 13.5 - B: 27 - C: 23.2</p>
 <p>C4056 TIPO DELCO REMY C/DEPRESOR A: 16.8 - B: 31.5 - C: 30</p>	 <p>C4057 TIPO MITSUBISHI C/DEPRESOR A: 16.9 - B: 34 - C: 29</p>	 <p>C4060 TIPO KOMATSU A: 16.8 - B: 35 - C: 31.7</p>	 <p>C4061 A: 17.5 - B: 33.4 - C: 21.8</p>
 <p>C4062 TIPO MITSUBISHI A: 17.4 - B: 26 - C: 30.7</p>	 <p>C4063 A: 17 - B: 26 - C: 24.5</p>	 <p>C4064 A: 16.9 - B: 31 - C: 27.1</p>	 <p>C4070 A: 17.2 - B: 29.5 - C: 34.4</p>

COLECTORES

 <p>C4071 TIPO DELCO REMY A: 17.3 - B: 30 - C: 27.8</p>	 <p>C4072 TIPO HITACH A: 14 - B: 27 - C: 331</p>	 <p>C4073 TIPO NIPPONDENSO A: 8.8 - B: 14.5 - C: 23</p>	 <p>C4074 TIPO ISUZU A: 16 - B: 32 - C: 29</p>
 <p>C4075 TIPO ISUZU A: 17 - B: 34 - C: 30</p>	 <p>C4076 TIPO ISUZU A: 16.7 - B: 34.5 - C: 29.5</p>	 <p>C4077 TIPO FORD 4G SERIES IR/IF A: 6 - B: 16 - C: 34</p>	 <p>C4078 A: 17.4 - B: 27 - C: 33</p>
 <p>C4079 TIPO MOTOROLA / PRESTOLITE A: 10 - B: 24.9 - C: 21.9</p>	 <p>C4080 TIPO MITSUBISHI A: 16.8 - B: 33.5 - C: 29.3</p>	 <p>C4081 TIPO FORD 6G A: 13.4 - B: 27 - C: 37</p>	 <p>C4082 A: 6.5 - B: 16 - C: 51.6</p>
 <p>C4083 A: 19.7 - B: 41.5 - C: 29.3</p>	 <p>C4084 TIPO MITSUBISHI A: 16.7 - B: 41.4 - C: 29</p>	 <p>C4085 A: 17 - B: 32.2 - C: 34</p>	 <p>C4086 A: 13.3 - B: 27.1 - C: 34.7</p>
 <p>C4087 A: 17 - B: 29.6 - C: 41.5</p>	 <p>C4088 A: 7 - B: 15 - C: 52</p>	 <p>C4089 A: 12.4 - B: 23.7 - C: 30</p>	 <p>C4090 A: 6.8 - B: 14.9 - C: 20.8</p>
 <p>C4091 A: 15.1 - B: 26.6 - C: 31.7</p>	 <p>C4092 A: 6.2 - B: 14.5 - C: 24</p>	 <p>C4093 TIPO ISUZU A: 16.8 - B: 34.5 - C: 28.5</p>	 <p>C4094 A: 17 - B: 28 - C: 22</p>

COLECTORES

 <p>C4095 A: 6 - B: 14.6 - C: 46</p>	 <p>C4096 A: 16.6 - B: 33.6 - C: 31.1</p>	 <p>C4097 A: 6.8 - B: 15 - C: 46</p>	 <p>C4098 A: 6.3 - B: 14.8 - C: 50</p>
 <p>C4099 A: 7 - B: 14.5 - C: 46</p>	 <p>C4100 A: 5.2 - B: 13.7 - C: 46.2</p>	 <p>C4101 A: 5.2 - B: 13.9 - C: 42.7</p>	 <p>C4102 A: 8.9 - B: 14.7 - C: 41.7</p>
 <p>C4103 A: 7 - B: 15.9 - C: 51.8</p>	 <p>C4104 A: 16.6 - B: 28.4 - C: 38.2</p>	 <p>C4105 A: 25.3 - B: 41.4 - C: 24.6</p>	 <p>C4116 A: 16 - B: 31.4 - C: 28.8</p>
 <p>C4117 A: 20.2 - B: 32.4 - C: 22</p>	 <p>C4118 A: 16.7 - B: 34.4 - C: 28.3</p>	 <p>C4119 A: 17.9 - B: 32.4 - C: 30.2</p>	 <p>C4120 TIPO ARGELITE / WAPSA A: 17 - B: 36 - C: 18.5</p>
 <p>C4122 TIPO INDIEL A: 10 - B: 25.4 - C: 21.5</p>	 <p>C4123 A: 16.7 - B: 32.4 - C: 29.7</p>	 <p>C4124 A: 16.77 - B: 28.4 - C: 31.9</p>	 <p>C4125 A: 17 - B: 28.5 - C: 33.1</p>
 <p>C4126 A: 8.3 - B: 15.7 - C: 24.5</p>	 <p>C4127 A: 20.4 - B: 33.5 - C: 32.6</p>	 <p>C4128 A: 6 - B: 16 - C: 35.5</p>	 <p>C4129 A: 18.4 - B: 29.9 - C: 26</p>

COLECTORES

C4130

A: 16.6 - B: 28 - C: 22.1

C4131

A: 8.5 - B: 14.7 - C: 20.3

C4132

A: 25.5 - B: 41.5 - C: 29.4

ESPACIADORES

E3004

TIPO ARGELITE / GAREF (INT. TAPA FINO) Ø25X8.3MM. EJE 17MM.

E3007

TIPO ARGELITE (POLEA GRUESO) Ø22X12.7MM. EJE 17.1MM.

E3012

SEGURO SEGER EJE ROTOR TIPO NASHVILLE

E3012/10

IDEM (CANT. 10)

E3030

TIPO INDIEL 90/100A. TAUNUS, M. BENZ (RULEMAN 6205 - ALTO 20MM. ESCALONADO)

E3031

TIPO INDIEL 100A. TAUNUS, M. BENZ. (ENTRE TAPA Y TURBINA) ALTO 12.2MM. EJE 17MM.

E3033

TIPO INDIEL, FALCON, PERKINS, M. BENZ, PEUGEOT (INTERMEDIO) ALTO 9.5MM. EJE 17MM.

E3034

TIPO GAREF - INDIEL (E/ TURBINA Y TAPA) Ø23.8X10MM. EJE 17MM.

E3039

TIPO GAREF - INDIEL (E/ TURBINA Y TAPA) Ø22X8.5MM. EJE 17MM.

E3043

TIPO INDIEL M. BENZ (E/ TURBINA Y TAPA) Ø30X10MM. EJE 17MM.

E3045

TIPO INDIEL 38/55A. (E/ ROTOR Y TAPA) Ø22X5.5MM. EJE 17MM.

E3050

TIPO HITACHI, CHEVROLET CORSA DIESEL (LADO TURBINA) Ø30X4MM. EJE 17MM.

E3063

FIAT 600 DINAMO Ø20X5MM. EJE 12MM.

E3064

TIPO NASHVILLE (GRUESO) Ø30X12MM. EJE 17MM.

E3065

TIPO NASHVILLE (FINO) Ø30X5.3MM. EJE 17MM.

E3071

DINAMO FIAT 1500 Ø226.4MM. EJE 15MM.

E3072

JUEGO ESPACIADORES ALTERNADOR TIPO INDIEL M. BENZ

E3073

JUEGO ESPACIADORES ALTERNADOR TIPO INDIEL 55/70A

E3074

JUEGO ESPACIADORES ALTERNADOR TIPO INDIEL 100A. (RULEMAN 6205)









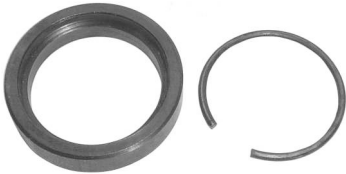

E3075

JUEGO ESPACIADORES ALTERNADOR TIPO GAREF

E3076

TIPO BOSCH 55A. M. BENZ (LADO TURBINA) Ø30X8MM. EJE 17MM.

ESPACIADORES

 <p>E3077 TIPO BOSCH 55A. M. BENZ (LADO ROTOR INTERIOR TAPA) Ø40X10MM. EJE 17MM.</p>	 <p>E3078 TIPO BOSCH / WAPSA 75A. (E/ ROTOR Y TAPA) Ø40X8.5MM . EJE 30MM.</p>	 <p>E3079 TIPO BOSCH (ESCALONADO) ALTO 5.5MM. EJE 17MM.</p>	 <p>E3080 TIPO BOSCH 55/70A. Ø28X8MM. EJE 17MM.</p>
 <p>E3087 TIPO BOSCH 125/140A. Ø40X18MM. EJE 30MM.</p>	 <p>E3088 TIPO INDIEL 90/100A. Ø30X8MM. EJE 17MM.</p>	 <p>E3089 TIPO BOSCH Ø30X5MM. EJE 17MM.</p>	 <p>E3090 TIPO TIPO BOSCH 140A. Ø40X10MM. EJE 30MM.</p>
 <p>E3091 TIPO TIPO BOSCH Ø42X5MM. EJE 17MM.</p>	 <p>E3092 TIPO M. MARELLI Ø25X3MM. EJE 17MM.</p>		

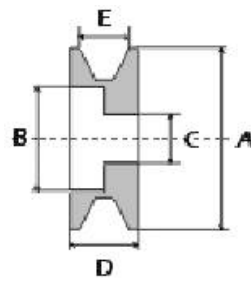

Código	Ø A	Ø B	Ø C	D	E	Canales	Chavetero	Observaciones
200010	71,0		17,0	20,0	10,0	1	-	Chapa 2 mitades
200011	87,5		17,0	26,0	10,0	1	-	Chapa 2 mitades
200012	71,0		17,0	20,0	10,0	1	-	Chapa 2 mitades
200014	71,0		17,0	20,0	10,0	1	-	Chapa
200020	74,0	35,0	17,0	21,5	10,0	1	4,0	
200021	74,0	35,0	15,0	21,5	10,0	1	4,0	
200022	82,0	35,0	17,0	23,0	13,0	1	4,0	
200023	104,0	36,0	17,0	23,5	13,0	1	4,0	
200024	80,5	35,0	17,0	25,5	19,0	1	4,0	
200025	68,0	32,0	17,0	28,0	17,0	1	4,0	
200026	99,5	53,0	17,0	40,0	13,0	2	4,0	
200027	113,0	72,0	17,0	21,5	10,0	1	4,0	
200028	90,5	45,0	17,0	22,0	13,0	1	4,0	
200029	82,5	36,0	17,0	27,0	13,0	1	4,0	
200030	62,0	38,0	17,0	20,0	10,0	1	4,0	
200031	75,0	36,0	15,0	25,0	10,0	1	4,0	
200032	75,0	40,0	17,0	19,0	10,0	1	4,0	
200033	79,5	31,0	17,0	26,5	17,0	1	4,0	
200034	8,5	39,5	17,0	43,0	13,0	2	4,0	
200035	84,0	39,0	17,0	24,5	17,0	1	4,0	
200036	71,0	37,0	17,0	19,0	10,0	1	4,0	
200037	81,5	35,5	17,0	31,0	10,0	2	4,0	
200038	70,0	35,0	17,0	31,5	10,0	1	4,0	
200039	100,0	66,5	17,0	23,5	10,0	1	-	
200040	100,0	52,5	17,0	35,0	10,0	2	4,0	
200041	71,0	37,0	17,0	15,6	10,0	1	4,0	
200051	70,0	35,0	17,0	34,0	10,0	2	-	
200052	91,0	36,0	17,0	38,0	13,0	2	-	
200053	78,0-97,0	36,0	17,0	31,0	13,0	2	-	2 Ø exterior
200054	76,0	35,0	17,0	40,0	13,0	2	-	
200055	117,0	60,0	25,0	36,0	13,0	2	5,0	
200056	128,0	91,0	22,2	49,0	13,0	2	5,0	
200057	115,0	70,0	Cónico	33,0	13,0	2	5,0	
200058	73,0	37,0	17,0	52,0	10,0	1	4,0	
200059	74,0	35,0	17,0	20,5	10,0	1	4,0	
200060	91,5	47,0	22,2	49,0	13,0	2	5,0	
200061	92,0	55,0	25,0	38,5	13,0	2	5,0	
200062	130,0	91,0	30,0	46,5	13,0	2	8,0	
200063	90,0	34,0	17,0	37,0	10,0	1	-	
200064	97,0	65,5	22,2	30,0	10,0	1	-	
200065	107,5		15,0	32,0	10,0	1	3,0	Chapa c/turb.
200066	97,0	55,0	17,0	38,0	13,0	2	-	
200067	80,0	42,0	25,0	34,5	13,0	2	5,0	
200068	68,0	36,0	17,0	35,0	10,0	1	-	

Poleas en V

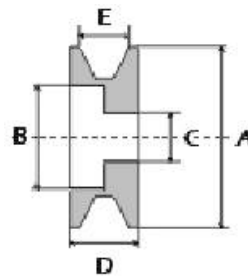

Código	Ø A	Ø B	Ø C	D	E	Canales	Chavetero	Observaciones
200069	76,0	40,0	17,0	36,0	13,0	2	4,0	
200070	99,0	53,0	17,0	38,0	13,0	2	-	
200071	94,5	34,8	22,2	35,0	13,0	2	4,0	
200072	82,5	34,8	22,2	35,0	13,0	2	4,0	
200073	80,0	40,0	17,0	19,0	13,0	1	-	
200074	90,0	-	22,2	33,5	13,0	1	-	
200075	84,5	39,5	22,2	43,5	13,0	2	4,0	
200076	83,8	39,0	17,0	25,5	17,0	1	-	
200077	86,0	47,0	17,0	31,0	10,0	2	-	
200078	92,0	53,0	30,0	36,0	13,0	2	8,0	
200079	74,0	35,0	17,0	16,0	10,0	1	4,0	

Poleas multivias

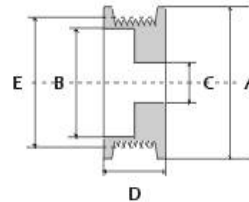

Código	Ø A	Ø B	Ø C	D	Ø E	Canales	Chavetero	Observaciones
M0100	72,5	49,0	17,0	31,5	66,5	7	-	Profundidad 10,5
M0100R	72,5	49,0	17,0	31,5	66,5	7	-	Profundidad 14,5
M0101	65,5	42,0	17,0	42,5	59,0	5	-	
M0102	66,0	45,0	17,0	34,0	60,0	5	-	
M0103	63,5	37,0	17,0	39,5	58,0	8	4,0	
M0104	68,0	47,0	17,0	30,0	62,0	6	-	
M0105	84,0	60,0	22,2	38,5	78,0	8	5,0	
M0106	66,0	45,0	17,0	29,5	59,5	6	-	
M0107	67,0	45,0	17,0	29,5	62,8	6	-	
M0108	65,0	44,0	17,0	26,5	59,5	5	-	
M0109	57,0	39,5	17,0	25,5	54,5	6	-	
M0110	70,0	47,5	17,0	21,0	64,5	4	-	
M0111	61,0	42,0	17,0	37,5	56,0	6	-	
M0112	55,0	33,5	17,0	44,5	50,0	6	-	
M0113	64,5	42,0	17,0	35,0	57,5	6	-	
M0114	61,0	40,0	17,0	35,0	55,0	6	-	
M0115	60,0	39,0	17,0	28,5	55,0	3	-	
M0116	65,0	44,0	17,0	35,0	60,0	8	-	
M0117	66,5	49,0	17,0	29,0	66,5	7	-	
M0118	72,0	38,5	17,0	44,0	66,7	8	-	
M0119	55,0	36,0	17,0	27,5	49,0	6	-	
M0120	55,0	36,0	17,0	41,0	49,0	6	-	
M0121	62,5	45,0	17,0	27,3	57,0	6	-	
M0122	60,0	41,0	17,0	39,0	54,5	6	-	

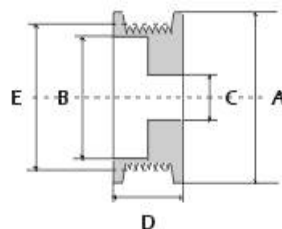
Poleas multivias

Código	Ø A	Ø B	Ø C	D	Ø E	Canales	Chavetero	Observaciones
M0123	58,5	41,0	17,0	26,0	56,0	6	-	
M0124	57,0	40,0	17,0	25,5	54,5	6	-	
M0125R	58,5-76,0	42,0	17,0	40,0	55,0	6	-	2 Ø exterior
M0126	84,5	65,3	17,0	37,0	76,8	9	-	
M0127	92,0	63,0	30,0	35,5	86,5	8	8,0	
M0128	63,5	45,0	17,0	41,3	57,5	8	-	
M0129	72,0	50,0	17,0	34,0	70,0	8	-	
M0130	79,0	58,0	17,0	37,5	70,0	8	-	
M0131	80,0-84,0	60,0	17,0	42,0	77,0	9	-	2 Ø exterior
M0132R	58,5-76,0	42,0	17,0	40,0	55,0	5	-	2 Ø exterior
M0133	48,8	36,0	17,0	31,0	48,8	6	-	
M0134	91,0	66,5	30,0	35,5	86,5	8	8,0	
M0135	68,0	43,0	17,0	38,8	61,5	5	-	
M0136	55,0	35,0	17,0	43,0	50,0	6	-	
M0137	85,3	51,0	17,0	36,5	80,5	8	-	
M0138	66,0	45,0	17,0	39,0	59,5	4	-	
M0139	96,5	76,0	30,0	40,0	89,5	9	-	
M0140	59,7	41,0	17,0	42,0	55,0	6	-	
M0141	74,5	47,0	17,0	42,0	68,0	6	-	

POLEAS EN V

<p>REFERENCIAS</p>			
<p>200014 TIPO INDIEL - PEUGEOT, GACEL, RENAULT, FORD, UNIVERSAL (CHAPA) A: Ø71 - C: Ø17 - D: 20 - E: 10</p>	<p>200010 TIPO GAREF / INDIEL - FALCON, PEUGEOT (AG-20) UNIVERSAL (CHAPA) A: Ø71 - C: Ø17 - D: 20 - E: 10</p>	<p>200011 TIPO GAREF - FIAT (AG-22) (CHAPA) A: Ø87.5 - C: Ø17 - D: 26 - E: 10</p>	<p>200012 FIAT DUNA (CHAPA) A: Ø71 - C: Ø17 - D: 20 - E: 10</p>
<p>200014 TIPO INDIEL - PEUGEOT, GACEL, RENAULT, FORD, UNIVERSAL (CHAPA) A: Ø71 - C: Ø17 - D: 20 - E: 10</p>	<p>200020 TIPO NASHVILLE - PEUGEOT, UNIVERSAL A: Ø74-B: Ø35 C: Ø17-D: 21.5-E: 10</p>	<p>200021 TIPO NASHVILLE - PEUGEOT, UNIVERSAL A: Ø74-B: Ø35 C: Ø15-D: 21.5-E: 10</p>	<p>200022 TIPO NASHVILLE - PERKINS A: Ø82 - B: Ø35 C: Ø17 - D: 23 - E: 13</p>
<p>200023 TIPO NASHVILLE, M. BENZ A: Ø104-B: Ø36 C: Ø17-D: 23.5-E: 13</p>	<p>200024 TIPO NASHVILLE, M. BENZ 3500 - A: Ø80.5-B: Ø35 C: Ø17-D: 26-E: 19.5</p>	<p>200025 TIPO NASHVILLE, BEDFORD - A: Ø68-B: Ø32 C: Ø17-D: 28-E: 16</p>	<p>200026 TIPO NASHVILLE, M. BENZ - A: Ø99.5-B: Ø53 C: Ø17-D: 39.5-E: 13</p>
<p>200027 TIPO NASHVILLE - MERCEDES BENZ 1112 A: Ø113-B: Ø72 C: Ø17-D: 21-E: 10</p>	<p>200028 TIPO INDIEL - M. BENZ 608/1112/1114 A: Ø90.5-B: Ø45 C: Ø17-D: 22-E: 13</p>	<p>200029 TIPO INDIEL - FORD F6000/7000 MOTOR PERKINS A: Ø82.5-B: Ø36.5 C: Ø17-D: 27-E: 13</p>	<p>200030 TIPO INDIEL - CITROEN 3CV A: Ø62-B: Ø38.5 C: Ø17-D: 20-E: 10</p>
<p>200031 TIPO INDIEL - PEUGEOT 404, FAIRLANE, TORNADO A: Ø75-B: Ø36 C: Ø15-D: 24.5-E: 10</p>	<p>200032 TIPO INDIEL - FALCON TODOS A: Ø75-B: Ø40 C: Ø17-D: 19-E: 10</p>	<p>200033 TIPO INDIEL - FIAT 400/500/700/800 A: Ø79.5-B: Ø31 C: Ø17-D: 26.5 - E: 17</p>	<p>200034 TIPO INDIEL - FORD PERKINS 55A. A: Ø81-B: Ø39.5 C: Ø17-D: 43-E: 13</p>
<p>200035 TIPO INDIEL - BEDFORD DIESEL A: Ø84-B: Ø39 C: Ø17-D: 24.5-E: 17</p>	<p>200036 TIPO INDIEL - RENAULT 4/6/12, CHEVROLET, PEUGEOT, DODGE A: Ø71-B: Ø37.5 C: Ø17-D: 19-E: 10</p>	<p>200037 TIPO INDIEL - J. DEERE 5010/5020 A: Ø81.5-B: Ø35.5 C: Ø17-D: 31-E: 10</p>	<p>200038 TIPO INDIEL - PEUGEOT 504/505 DIESEL A: Ø70-B: Ø35 C: Ø17-D: 31.5-E: 10</p>

POLEAS EN V

 <p>200039 TIPO NASHVILLE - DEUTZ, MASSEY FERGUSON A:Ø100-B:Ø66.5 C:Ø17-D:23-E:10</p>	 <p>200040 TIPO NASHVILLE - DEUTZ, MASSEY FERGUSON A:Ø100-B:Ø52.5 C:Ø17-D:35-E:10</p>	 <p>200041 TIPO M. MARELLI - FIAT A:Ø71-B:Ø37.5 C:Ø17-D:15.6-E:10</p>	 <p>200051 TIPO INDIEL - PEUGEOT 504 DIESEL A:Ø70-B:Ø35 C:Ø17-D:33.5-E:10</p>
 <p>200052 TIPO INDIEL - MERCEDES BENZ A:Ø91-B:Ø36 C:Ø17-D:38-E:14</p>	 <p>200053 TIPO INDIEL - FIAT 600 A:Ø78/97-B:Ø36 C:Ø17-D:31-E:10</p>	 <p>200054 TIPO NASHVILLE - SCANIA A:Ø76-B:Ø35 C:Ø17-D:40-E:13</p>	 <p>200055 TIPO NASHVILLE - 125A. A/A A:Ø117-B:Ø60 C:Ø25-D:36-E:13</p>
 <p>200056 TIPO BOSCH / WAPSA - 75A. A:Ø128-B:Ø91 C:Ø22-D:49-E:13</p>	 <p>200057 TIPO NASHVILLE - 125A. (EJE CONICO) A:Ø115-B:Ø70-D:33-E:13</p>	 <p>200058 TIPO BOSCH - GACEL, ESCORT, RENALULT 19 A:Ø73-B:Ø37 C:Ø17-D:52-E:13</p>	 <p>200059 TIPO M. MARELLI - FIAT DUNA 1.7 A:Ø74-B:Ø35 C:Ø17-D:20.5-E:10</p>
 <p>200060 TIPO BOSCH / WAPSA - 24V. 75A. A:Ø91.5-B:Ø47 C:Ø22.2-D:49-E:14</p>	 <p>200061 TIPO NASHVILLE - 125A. A:Ø92-B:Ø55 C:Ø25-D:38.5-E:12.5</p>	 <p>200062 TIPO BOSCH / WAPSA - 105/125A. A:Ø130-B:Ø91 C:Ø30-D:46.5-E:12.5</p>	 <p>200063 TIPO NASHVILLE - FIAT 150 TURBO A:Ø90-B:Ø34 C:Ø17-D:37-E:10</p>
 <p>200064 TIPO WAPSA - 75A. 24V. A:Ø97-B:Ø65.5 C:Ø22.2-D:30-E:10</p>	 <p>200065 TIPO BOSCH / WAPSA - KOMBI VW (CHAPA C/ TURBINA) A: Ø107.5 - C: Ø15 - D: 32 - E: 10</p>	 <p>200066 TIPO BOSCH / WAPSA - OHL M. BENZ 1621 A:Ø97-B:Ø55 C:Ø17-D:38-E:13</p>	 <p>200067 TIPO NASHVILLE A:Ø80-B:Ø42 C:Ø25-D:34.5-E:13</p>
 <p>200068 TIPO M. MARELLI - RENAULT 9/11 A:Ø68-B:Ø36 C:Ø17-D:35-E:10</p>	 <p>200069 TIPO BOSCH - SCANIA A:Ø76-B:Ø40 C:Ø17-D:36-E:13</p>	 <p>200070 TIPO INDIEL - M. BENZ A:Ø99-B:Ø53 C:Ø17-D:37.5-E:13</p>	 <p>200071 TIPO PRESTOLITE A:Ø94.5-B:Ø34.8C:Ø22.2-D:35-E:13</p>

POLEAS EN V

 <p>200072 TIPO PRESTOLITE A:Ø52.5-B:Ø34.8C:Ø22.2-D:35.5-E:13</p>	 <p>200073 CHEVROLET CORSA DIESEL A:Ø80-B:Ø40 C:Ø17-D:19-E:13</p>	 <p>200074 JOHN DEERE A: Ø90 - C: Ø17 - D: 19 - E: 13</p>	 <p>200075 TIPO INDIEL - LEECE NEVILLE - 44707A01 A:Ø84.5-B:Ø39.5C:Ø22.2-D:43.5-E:13</p>
 <p>200076 TIPO ISUZU DIESEL A:Ø83.8-B:Ø39C:Ø17-D:25.5-E:17</p>	 <p>200077 TIPO BOSCH - 24V. 55A. OMNIBUS/CAMION SCANIA (SUECO) A:Ø86-B:Ø47 C:Ø17-D:31-E:10</p>	 <p>200078 TIPO BOSCH - SCANIA 24V. 140A. A:Ø92-B:Ø53 C:Ø30-D:36-E:13</p>	 <p>200079 TIPO M. MARELLI - FIAT A:Ø74-B:Ø35 C:Ø17-D:16-E:10</p>

POLEAS MULTIVIAS

 <p>Referencias de poleas multivías</p>	<p>7 Vías</p>  <p>M0100 MEDIA POLEA ALTERNADOR CHEVROLET C10, SPRINTER, DUCATO A:Ø72.5-B:Ø49 C:Ø17-D:31.5-E:66.5 M0100R IDEM (REFORZADA)</p>	<p>5 Vías</p>  <p>M0101 TIPO M. MARELLI - 100A. A:Ø64-B:Ø42 C:Ø17-D:42.5-E:59</p>	<p>5 Vías</p>  <p>M0102 TIPO M. MARELLI - 75A. A:Ø66-B:Ø45 C:Ø17-D:34-E:60</p>
<p>8 Vías</p>  <p>M0103 TIPO BOSCH / WAPSA - FORD CARGO, MOTOR CUMMINS. A:Ø63.5-B:Ø37 C:Ø17-D:39.5-E:58</p>	<p>6 Vías</p>  <p>M0104 TIPO BOSCH - 85A. A:Ø68-B:Ø46 C:Ø17-D:30-E:62</p>	<p>8 Vías</p>  <p>M0105 TIPO BOSCH - DEUTZ C/ MOTOR CUMMINS A:Ø84-B:Ø60 C:Ø22.2-D:38.5-E:78</p>	<p>6 Vías</p>  <p>M0106 TIPO VALEO - RENAULT 19 A:Ø66-B:Ø45 C:Ø17-D:29.5-E:59.5</p>
<p>6 Vías</p>  <p>M0107 TIPO VALEO - PEUGEOT 406 TD A:Ø67-B:Ø45 C:Ø17-D:29.5-E:62.8</p>	<p>5 Vías</p>  <p>M0108 FORD FIESTA / KA A:Ø65-B:Ø44 C:Ø17-D:26.5-E:59.5</p>	<p>6 Vías</p>  <p>M0109 TIPO VALEO - PEUGEOT 206 / PARTNER A:Ø57-B:Ø39 C:Ø17-D:25.5-E:54.5</p>	<p>4Vías</p>  <p>M0110 TIPO BOSCH - FIAT TEMPRA A:Ø70-B:Ø48 C:Ø17-D:21-E:64.5</p>



POLEAS MULTIVIAS

<p>6 Vías</p>  <p>M0111 TIPO BOSCH - VW POLO /GOLF MOD. NUEVO A:Ø61-B:Ø42 C:Ø17-D:37.5-E:56</p>	<p>6 Vías</p>  <p>M0112 TIPO INDIEL - POLO A/A-35214319 A:Ø55-B:Ø35 C:Ø17-D:44.5-E:50</p>	<p>6 Vías</p>  <p>M0113 TIPO INDIEL - VW GOL - 35214461 A:Ø64.4-B:Ø42 C:Ø17-D:35-E:57.5</p>	<p>6 Vías</p>  <p>M0114 TIPO INDIEL - RENAULT 19 / CLIO 35214244 A:Ø61-B:Ø40 C:Ø17-D:35-E:55</p>
<p>3 Vías</p>  <p>M0115 TIPO INDIEL - FIESTA DIESEL - 35214371 A:Ø60-B:Ø39 C:Ø17-D:28.5-E:55</p>	<p>8 Vías</p>  <p>M0116 TIPO INDIEL - CUMMINS ZANELLO - 4462 A:Ø65-B:Ø44 C:Ø17-D:35-E:60</p>	<p>7 Vías</p>  <p>M0117 TIPO INDIEL - PICK UP C20 CUMMINS A:Ø66.5-B:Ø51.5 C:Ø17-D:44-E:66.7</p>	<p>8 Vías</p>  <p>M0118 TIPO BOSCH - CATERPILLAR A:Ø60-B:Ø41 C:Ø17-D:39-E:54.5</p>
<p>6 Vías</p>  <p>M0119 TIPO BOSCH - 120A. CHEVROLET VECTRA A:Ø55-B:Ø36 C:Ø17-D:27.5-E:49</p>	<p>6 Vías</p>  <p>M0120 TIPO VALEO - 70A. VW POLO S/A / GOLF 2000 / TRANSPORTE A:Ø55-B:Ø36 C:Ø17-D:41-E:49</p>	<p>6 Vías</p>  <p>M0121 TIPO BOSCH - 90A. GOL 2000 A:Ø62.5-B:Ø45 C:Ø17-D:26.8-E:57</p>	<p>6 Vías</p>  <p>M0122 TIPO VALEO - 80A. DUCATO, RENAULT A:Ø60-B:Ø41 C:Ø17-D:39-E:54.5</p>
<p>6 Vías</p>  <p>M0123 TIPO BOSCH - PEUGEOT 80A A:Ø58.5-B:Ø41 C:Ø17-D:26-E: 56</p>	<p>6 Vías</p>  <p>M0124 TIPO VALEO - PEUGEOT 206 NAFTA A:Ø57-B:Ø40 C:Ø17-D:25.5-E:54.5</p>	<p>6 Vías</p>  <p>M0125R RENAULT KANGOO (REFORMA) A:Ø58.5/76-B:Ø42 C:Ø17-D:40-E:55</p>	<p>9 Vías</p>  <p>M0126 MOTOR CUMMINS 1114 A:Ø83.5-B:Ø65 C:Ø17-D:37-E:76.8</p>
<p>8 Vías</p>  <p>M0127 TIPO BOSCH - M. BENZ, SCANIA A:Ø92-B:Ø63 C:Ø30-D:35.5-E:86.5</p>	<p>8 Vías</p>  <p>M0128 TIPO BOSCH - 80A. 24V. M. BENZ A:Ø63.5-B:Ø45 C:Ø17-D:41.3-E:57.5</p>	<p>8 Vías</p>  <p>M0129 TIPO BOSCH - 140A. 24V. SCANIA A:Ø72-B:Ø50 C:Ø17-D:34-E:70</p>	<p>8 Vías</p>  <p>M0130 TIPO BOSCH - (ESPAÑOL) M. BENZ ELECTRONICO A:Ø79-B:Ø58 C:Ø17-D:37.5-E:70</p>
<p>9 Vías</p>  <p>M0131 TIPO BOSCH - (ESPAÑOL) M. BENZ ELECTRONICO A:Ø80/84-B:Ø60 C:Ø17-D:42-E:77</p>	<p>5 Vías</p>  <p>M0132R RENAULT CLIO 2 (REFORMA) A:Ø58.5/76-B:Ø42 C:Ø17-D:40-E:55</p>	<p>6 Vías</p>  <p>M0133 PEUGEOT NAFTA A:Ø48.8-B:Ø36 C:Ø17-D:31-E:48.8</p>	<p>8 Vías</p>  <p>M0134 TIPO BOSCH - 140A A:Ø91-B:Ø66.5 C:Ø30-D:35.5-E:86.5</p>

POLEAS MULTIVIAS

<p>5 Vías</p>  <p>M0135 TIPO M. MARELLI - FIAT FIORINO A:Ø68-B:Ø43 C:Ø17-D:38.8-E:61.5</p>	<p>6 Vías</p>  <p>M0136 TIPO BOSCH - 90A. VW GOL / SAVEIRO / POLO / FOX A:Ø55-B:Ø35 C:Ø17-D:43.3-E:50</p>	<p>8 Vías</p>  <p>M0137 TIPO BOSCH - SCANIA A:Ø85.3-B:Ø61C:Ø17-D:36.5-E:80.5</p>	<p>4 Vías</p>  <p>M0138 TIPO NIPPONDENDO / M. MARELLI - FIAT FIORINO TURBODIESEL A:Ø66-B:Ø45 C:Ø17-D:39-E:59.5</p>
<p>9 Vías</p>  <p>M0139 TIPO BOSCH - 140A. VOLVO A:Ø96.5-B:Ø76 C:Ø30-D:40-E:89.5</p>	<p>6 Vías</p>  <p>M0140 LOGAN / SANDERO A:Ø59.7-B:Ø41 C:Ø17-D:42-E:55</p>	<p>6 Vías</p>  <p>M0141 FIAT, IVECO DAILY A:Ø74.5-B:Ø47 C:Ø17-D:42-E:68</p>	<p>8 Vías</p>  <p>M0142 JOHN DEERE 6605/7505 6 CILINDROS 12V. 90A. A:Ø55.2-B:Ø34.3 C:Ø17-D:36.7-E:50</p>

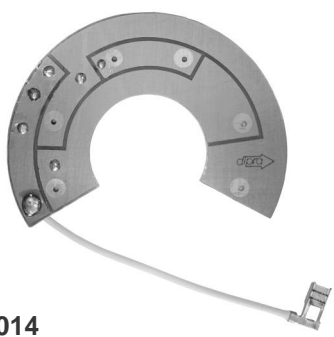
PLAQUETA CIRCUITO IMPRESO

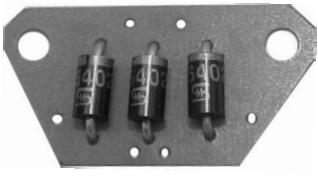
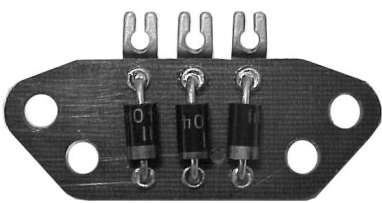
 <p>361014 ALTERNADOR TIPO NASVILLE 55/70A.</p>	 <p>361015 ALTERNADOR TIPO NASHVILLE 55/70A. MOD. NUEVO</p>	 <p>361501 ALTERNADOR TIPO INDIEL 38/55A.</p>
 <p>361502 ALTERNADOR TIPO INDIEL 70A.</p>	 <p>361504 ALTERNADOR TIPO INDIEL 90/100A.</p>	

PORTA ESCOBILLAS DE ALTERNADOR

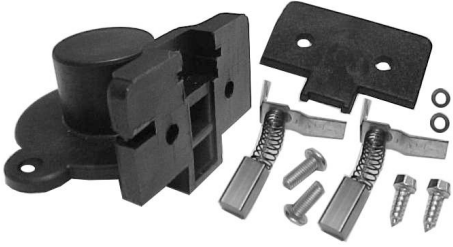

P7001
1 JUEGO ALT. ARGELITE COMPLETO

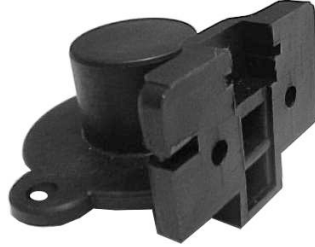

P7001/1
ALTERNADOR ARGELITE
PARA REGULADOR INCORPORADO

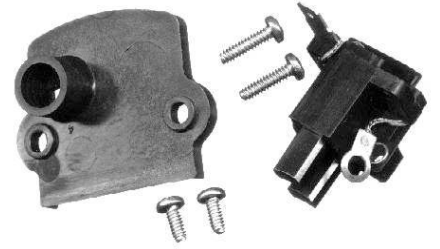

P7004
ALT. INDIEL 28/55/70 amp. FORD FALCON -
F100 - PERKINS - PEUG.- FIAT - COMPLETO



P7023
INDIEL 90 amp. - F. TAUNUS - M.BENZ compl.



P7024
INDIEL PORTAESC. FORD - VW - FIAT -
RENAULT



P7111
ALT. DELCO - CHEVROLET - GM - DAEWO -
1.101.218, 10.480.125 5x8x22 10472881 /
10473364 / 10490180



P7112
ALT. CHRYSLER 90-120 AMP 5.8 X 5.8 X13



P7113
ALT. DELCO -
MERCEDES BENZ - 5x6x22 1979724,10467934



P7114
ALT. NASHVILLE - DEUTZ- PERKINS - FIAT- etc
MODELO VIEJO - 1 SALIDA - CARBON ALE 13

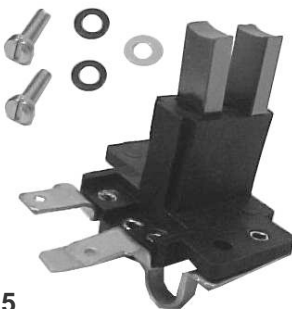

P7115
ALTERNADOR NASHVILLE M. BENZ - CON 3
TERMINALES

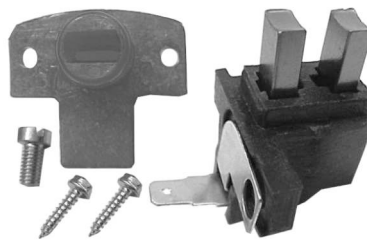

P7116
ALTERNADOR GAREF FIAT - PEUGEOT -
COMPLETO



P7117
ALT. T. DELCO REMY 22 SI-MLX 5.5 X 8 X 48.5

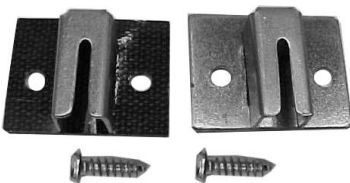

P7118
1 JUEGO P/REPARAR TAPA ALT. PRESTOLITE



P7119
ALT. T. DELCO REMY 4.6 X 8 X 25

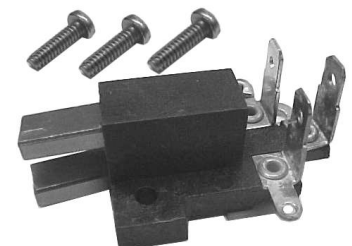

P7120
ALT. INDIEL M.BENZ

PORTA ESCOBILLAS DE ALTERNADOR

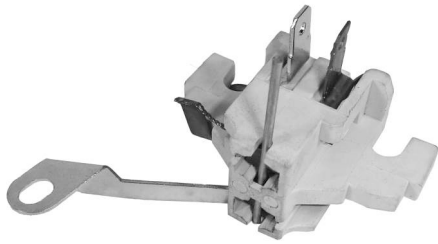

P7121
ALT. T. DELCO REMY 5 X 8 X 13



P7122
ALT. T. DELCO REMY 5 X 8 X 13



P7124
ALT. DELCO - CHEVROLET - GM - DAEWO
ORIGEN COREA - 100amp. - 4.5x8x22
10475011



P7125
ALT. DELCO - CHEVROLET - GM
104.750.11, 4.5x8x22 10475746

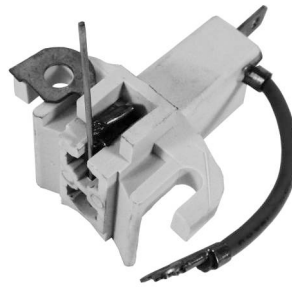

P7126
ALT. FORD 70 - 100 AMP 4 X 7.6 X 13

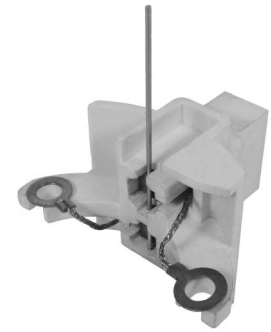

P7127
ALT. FORD MOTORCRAFT 40-65 AMP.



P7128
NASHVILLE PARA REGULAD. INCORPORADO
M. BENZ



P7129
ALT. NASHVILLE 125 AMP. M. BENZ - SCANIA



P7130
ALT. HITACHI 5 X 8 X 24



P7131
ALT. HITACHI NISSAN 5 X 8 X 26.5



P7132
ALT. HITACHI 5 X 8 X 26.4



P7133
ALT. HITACHI 5 X 8 X 25



P7134
ALT. HITACHI 5 X 7 X 15



P7135
ALT. HITACHI CORSA DIESEL 5 X 8 X 22

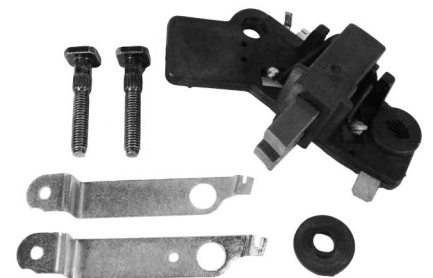

P7136
ALT. HITACHI 5 X 7 X 15.5

PORTA ESCOBILLAS DE ALTERNADOR



P7137
ALT. HITACHI 5.2 X 9.2 X 28.5

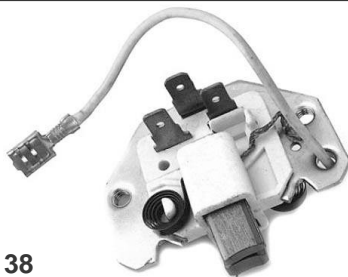

P7138
ALT. BOSCH 12V. - M. BENZ - M. FERGUSON -
VW AGRALE-MAXION-KOMATSU 5x10x17
1 124 336 050

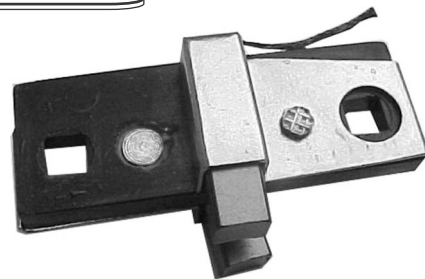

P7139
ALT. WAPSA FORD F100/F4000 6.3x6.3x12.7
419001



P7140
ALTERNADOR DELCO - FIAT - CHEVETTE -
OPALA - 5x8x13.2 3472316



P7141
ALTERNADOR BOSCH 24V. - M. BENZ - FIAT -
SCANIA VOLVO - MWM - 5x10x17 1 124 336



P7142
ALTERNADOR DELCO SERIE - IR / EF -
CHEVROLET - GM. MONZA 5x8x16.5
1876876.D776.1984462



P7143
WAPSA - CAMIONES VW - FORD 6.3x6.3x12.7
419008



P7144
INDIEL PEUGEOT 405 - RENA.: Clio Full / 1.6c /
Ar-cond. 97 >01 / R.9 1.6 94
VOLKSW.: Gol 1.6 / 1.8 / 2.0 / c/ac.Motor 827 84
5x8x26 352.14.128

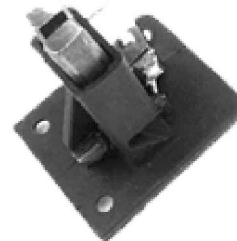

P7145
BOSCH VOLKSWAGEN - KOMBI - SENDA /
BRASILIA / GOL / SAVEIRO 5x18x15
9 121 080 281

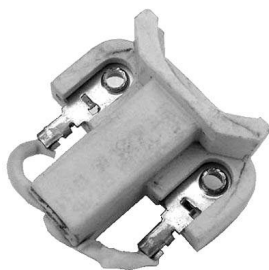

P7146
FORD - F250 / F350 / RANGER (F1D2-10347-
A-GB 320) IR/IF 36 SERIE - 4x7.5x18
F1DZ-10347-A



P7147
FORD - P/ ALTERNADORES 3G Series IR/IF
4x7.5x18.5 E9PU-10320-AA

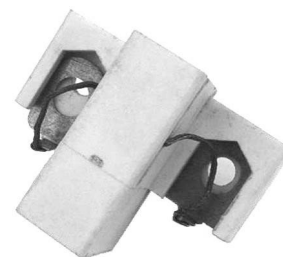

P7148
FORD - Número Original: E43Z-10320-A, GC-
402 - IR/IF 2G Series - 4x7.5x12 E43Z-
10320-A, GC-402

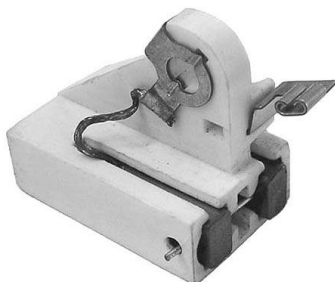

P7149
DELCO CHEVROLET - GM: OMEGA 4.1
5x8x22 1989702

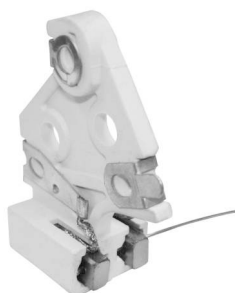

P7150
PORTA ESCOBILLAS ALTERNADOR DELCO



P7151
ALT. HITACHI 5 X 8 X 26.5

PORTA ESCOBILLAS DE ALTERNADOR

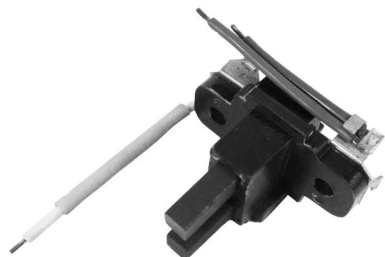

P7152
ALT. HITACHI 6 X 6 X 19,2



P7153
ALT. BOSCH. DODGE NEON MITSUBISHI.

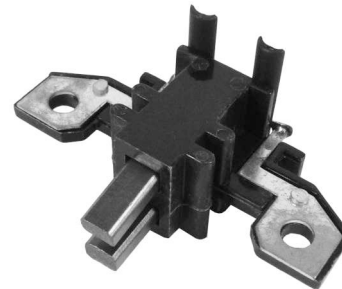

P7154
ALT. BOSCH. DODGE NEON MITSUBISHI.



P7155
ALT. NIPPONDENSO 5 X 7 X 15



P7156
ALT. NIPPONDENSO 5 X 7 X 15.5



P7157
ALT. NIPPONDENSO 5 X 7 X 15



P7158
ALT. 6 X 7 X 21

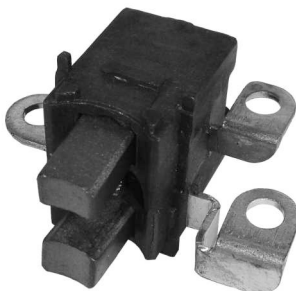

P7159
ALT. NIPPONDENSO 75 - 90 AMP 5 X 7 X 15



P7160
ALT. NIPPONDENSO 120 - 135 AMP 5 X 7 X 15



P7161
ALT. 5 X 6 X 13.8



P7162
ALT. 8.5 X 10.5 X 15



P7163
ALT. HITACHI 5 X 7 X 21.5



P7164
ALT. T. DELCO REMY 105AMP.
5.2 X 9.2 X 30.5



P7165
ALT. T. DELCO REMY 5 X 8 X 20.8



P7166
ALT. T. DELCO REMY 5.5 x 8.1 x 48.5

PORTA ESCOBILLAS DE ALTERNADOR



P7167
ALT. FORD: FIESTA, FOCUS, KA, ECOSPORT,
COURRIER 4,5 x 8,3 x 16,3



P7168
ALT. DELCO 27SI J. DEERE, KOMATSU,
LUCAS 5 X 4 X 15

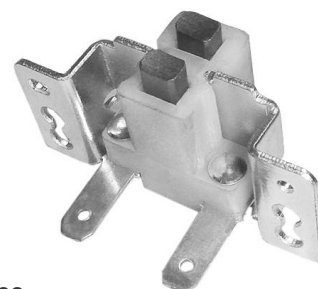

P7169
ALT. VALEO 4,5 X 6,4 X 15,5

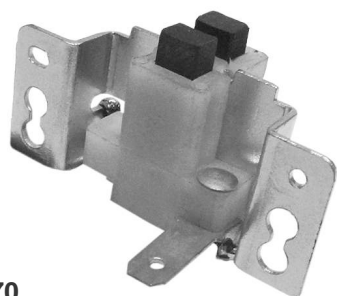

P7170
ALT. VALEO, MOTOROLA 8AL/P 8AR
5,3 X 6,8 X 15

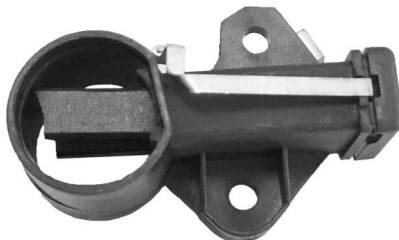

P7171
PORTAESCOBILLAS ALTERNADOR TIPO
DELCO REMY



P7172
PORTAESCOBILLAS ALTERNADOR TIPO
MITSUBISHI

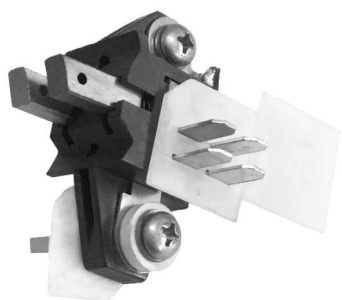

P7173
PORTAESCOBILLAS ALTERNADOR TIPO
MITSUBISHI



P7174
PORTAESCOBILLAS ALTERNADOR TIPO
FORD

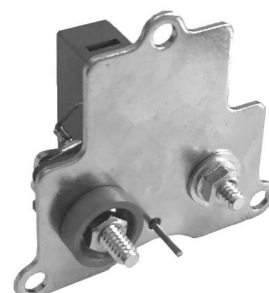

P7175
PORTAESCOBILLAS ALTERNADOR TIPO
FORD

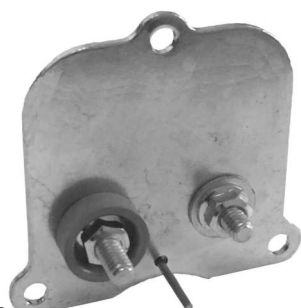

P7176
APORTAESCOBILLAS ALTERNADOR TIPO
FORD



P7177
PORTAESCOBILLAS ALTERNADOR TIPO
CHRYSLER



P7178
PORTAESCOBILLAS ALTERNADOR TIPO
CHRYSLER



P7179
PORTAESCOBILLAS ALTERNADOR TIPO
CHRYSLER - BOSCH

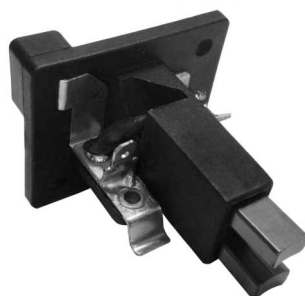

P7180
PORTAESCOBILLAS ALTERNADOR TIPO
BOSCH

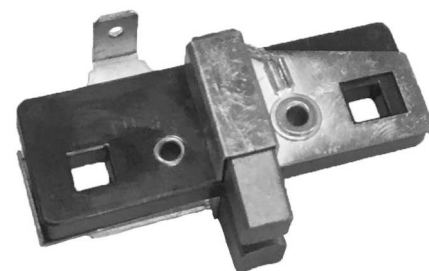

P7181
PORTAESCOBILLAS ALTERNADOR TIPO
BOSCH

PORTA ESCOBILLAS DE ALTERNADOR

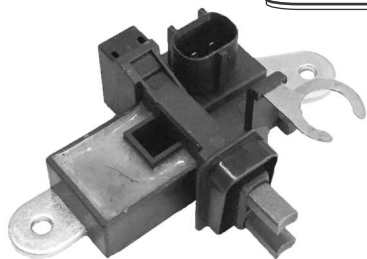

P7182
PORTAESCOBILLAS ALTERNADOR TIPO
BOSCH



P7183
PORTAESCOBILLAS ALTERNADOR TIPO
HITACHI



P7184
PORTAESCOBILLAS ALTERNADOR TIPO
HITACHI



P7185
PORTAESCOBILLAS ALTERNADOR TIPO
HITACHI



P7186
PORTAESCOBILLAS ALTERNADOR TIPO
HITACHI



P7187
PORTAESCOBILLAS ALTERNADOR TIPO
HITACHI

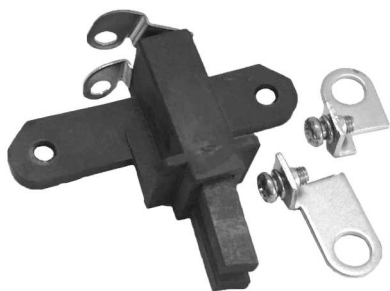

P7188
PORTAESCOBILLAS ALTERNADOR TIPO
HITACHI



P7189
PORTAESCOBILLAS ALTERNADOR TIPO
DELCO REMY

TAPAS PORTA ESCOBILLAS

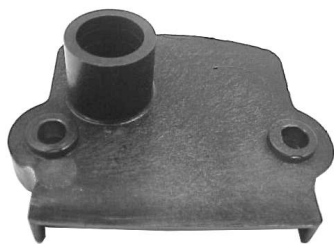

P7002
TAPA DE PORTAESCOBILLAS ALTERNADOR
TIPO INDIEL



P7022
TAPA CAJA PORTAESCOBILLAS
ALTERNADOR TIPO NASHVILLE



P7032
TAPA PORTAESCOBILLAS ALTERNADOR
TIPO INDIEL

TRABAS Y JUNTAS



P7037
TAPA DE CHAPA PORTAESCOBILLAS
ALTERNADOR TIPO INDIEL



P7010
TRABA ENCHUFE PORTAESCOBILLAS
ALTERNADOR TIPO NASHVILLE



P7032/10
JJUNTA DE CORCHO ALTERNADOR TIPO
INDIEL (CANT.10)

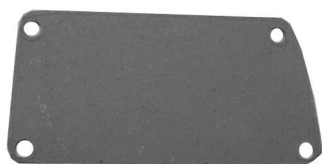

P7038
JUNTA TAPA PORTAESCOBILLAS
ALTERNADOR TIPO INDIEL (CANT.10)



P7042
TRABA ENCHUFE PORTAESCOBILLAS
ALTERNADOR TIPO INDIEL

TORNILLOS ARMADOS

T4002
TIPO ARGELITE SALIDA POSITIVO

T4005
TIPO INDIEL SALIDA LUZ PILOTO, AISLANTE PLASTICO
T4005P
TIPO INDIEL SALIDA LUZ PILOTO, AISLANTE PICADILLO

T4006
TIPO GAREF SALIDA INDICADOR CARGA CON REGULADOR INCORPORADO

T4011
TIPO PRESTOLITE, ARGELITE, SALIDA AUXILIAR, IGNICION

T4012
TIPO ARGELITE, PRESTOLITE, SALIDA POSITIVA

T4013
TIPO ARGELITE ARMADURA RENAULT 18 CON DETECTOR DE FALLAS, SALIDA POSITIVA

T4014
TIPO GAREF SALIDA Y FIJACION PLACA DIODO POSITIVA

T4019
TIPO NASHVILLE SALIDA POSITIVA 80/100A.

T4021
TIPO NASHVILLE SALIDA POSITIVO COMPLETO 55/70A.

T4022
TIPO GAREF SALIDA POSITIVO PEUGEOT 504, FORD, FIAT

T4023
TIPO GAREF, FORD, INDICADOR DE CARGA SIN REGULADOR INCORPORADO

T4024
TIPO INDIEL SALIDA POSITIVA 26/55/70A.

T4029
TIPO INDIEL SALIDA POSITIVA 90/100A.

TORNILLOS PLACA DIODOS

T6014
TORNILLO ALTERNADOR TIPO ARGELITE PLACA NEGATIVA

T6015
TORNILLOS ALTERNADOR TIPO GAREF PLACA NEGATIVA

T6025
TORNILLOS ALTERNADOR TIPO INDIEL PLACA NEGATIVA

T6035
TORNILLOS ALTERNADOR TIPO NASHVILLE PLACA PORTADIODOS

TORNILLOS PASANTES ALTERNADOR

T5005
ALTERNADOR TIPO MARELLI FIAT PALIO M6X86MM. (CANT. 3)

T5006
ALTERNADOR TIPO INDIEL 28/38/55A. FORD, PEUGEOT, RENAULT, M6X97MM. (CANT. 3)

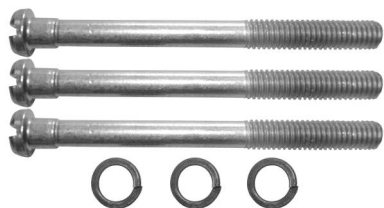
TORNILLOS PASANTES DE ALTERNADOR

T5007
ALTERNADOR TIPO INDIEL 55/70A. NF12X62MM. CABEZA CILINDRICA (CANT. 3)



T5008
ALTERNADOR TIPO BOSCH 125/140A. M6X99MM. (CANT. 4)



T5009
ALTERNADOR TIPO BOSCH/WAPSA 125/140A. M6X99MM. (CANT. 4)

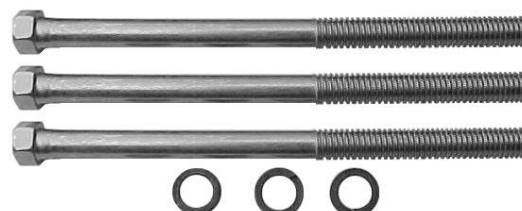

T5012
ALTERNADOR TIPO INDIEL M6X92MM. CABEZA HEXAGONAL (CANT. 3)

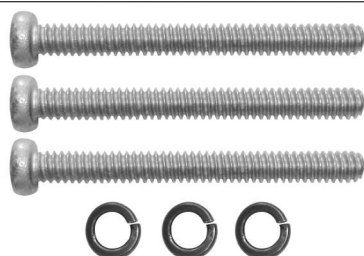

T5015
ALTERNADOR TIPO ARGELITE CITROEN W3/16X48MM. CABEZA CILINDRICA (CANT. 3)



T5016
ALTERNADOR TIPO ARGELITE W3/16X68MM. CABEZA CILINDRICA (CANT. 4)

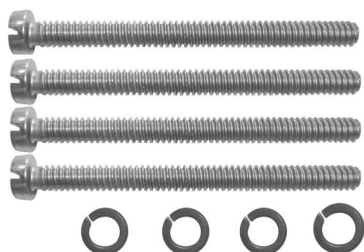

T5017
ALTERNADOR TIPO ARGELITE W3/16X58MM. (CANT. 4)



T5018
ALTERNADOR TIPO GAREF FIAT 600 M6X52MM. CABEZA MARTILLO (CANT. 3)



T5019
ALTERNADOR TIPO GAREF M6X92MM. CABEZA EXAGONAL (CANT. 3)



T5020
ALTERNADOR TIPO GAREF PEUGEOT M6X60MM. CABEZA MARTILLO (CANT. 3)



T5025
ALTERNADOR TIPO NDIEL 90/100A. M5X99MM. (CANT. 4)



T5026
ALTERNADOR TIPO NDIEL M6X76MM. CABEZA HEXAGONAL (CANT. 3)

TORNILLOS PASANTE DE ALTERNADOR

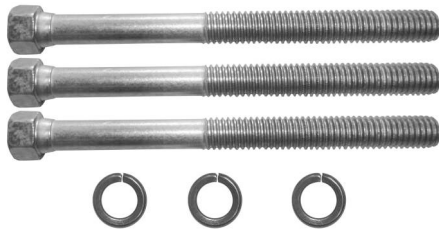

T5036
ALTERNADOR TIPO NDIEL M. BENZ M6X70MM. (CANT. 3)

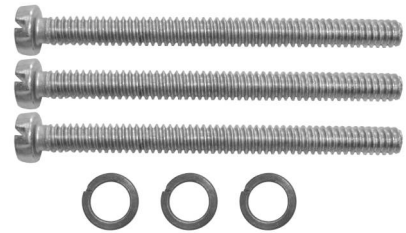

T5170
ALTERNADOR TIPO PRESTOLITE/ARGELITE W3/16X58MM. CABEZA CILINDRICA (CANT. 3)



T5171
ALTERNADOR TIPO NASHVILLE 35/55/70A. FIAT, M. BENZ, DEUTZ M5X65MM. (CANT. 3)



T5171A
ALTERNADOR TIPO NASHVILLE 35/55/70A. CABEZA ALLEN M5X65MM. (CANT. 3)

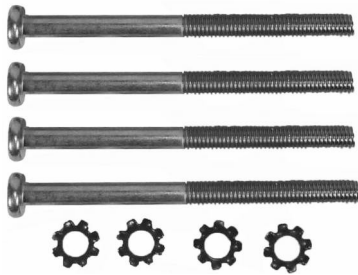

T5172
ALTERNADOR TIPO BOSCH M5X65MM. (CANT. 4)



T5172A
ALTERNADOR TIPO BOSCH M5X65MM. CABEZA ALLEN (CANT. 4)



T5177
ALTERNADOR TIPO NASHVILLE 125A. M6X92MM. (CANT. 4)

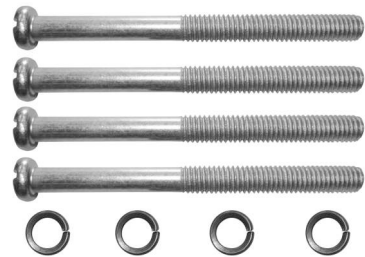

T5178
ALTERNADOR TIPO NASHVILLE 90/100A. M6X70MM. (CANT. 4)



T5179
ALTERNADOR TIPO NASHVILLE M6X76MM. CABEZA CILINDRICA (CANT. 3)



T5180
ALTERNADOR TIPO BOSCH 24V. WAPSA 75A. M6X76MM. (CANT. 4)



T5181
ALTERNADOR TIPO BOSCH 24V. WAPSA 75A. CABEZA ALLEN CON LLAVE M6X71MM. (CANT. 4)



T5182
ALTERNADOR TIPO BOSCH 24V. WAPSA 75A. M6X75MM. CABEZA ALLEN. (CANT. 4)

TORNILLOS PASANTE DE ALTERNADOR



T5201
ALTERNADOR TIPO BOSCH VARIOS M5X95MM. (CANT. 4)



T5202
ALTERNADOR TIPO BOSCH VARIOS M5X115MM. (CANT. 4)



T5204
ALTERNADOR TIPO BOSCH VARIOS M5X128MM.(CANT. 4)

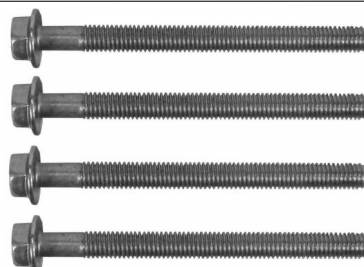

T5205
ALTERNADOR TIPO BOSCH M5X60MM. CABEZA HEXAGONAL (CANT.4)

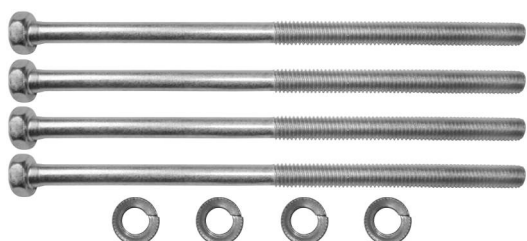

T5221
ALTERNADOR TIPO BOSCH VARIOS 24V. 90A. M6X125MM.
CABEZA HEXAGONAL (CANT. 4)



T5222
ALTERNADOR TIPO VALEO M5X42MM. CABEZA HEXAGONAL (CANT. 4)

TORNILLOS VARIOS



T7025
ALTERNADOR TIPO GAREF
SUJECION REGULADOR
INCORPORADO (CANT. 10)



T7210
SUJETA ALTERNADOR M. BENZ
M10X145MM.



T7210L
SUJETA ALTERNADOR M. BENZ
M10X170MM.



T7222
TRILOBULAR ALTERNADOR TIPO
INDIEL 1/2X6.32MM. (CANT. 50)



T7223
TRILOBULAR ALTERNADOR TIPO
INDIEL CORTO (CANT. 50)



T7224
AUTORROSCANTES RETEN
ALTERNADOR TIPO INDIEL
M4X12MM. (CANT. 50)



T7226
TRILOBULAR PORTAESCOBILLA
ALTERNADOR TIPO INDIEL 1/2
Y 5/16 (CANT. 4 - 2+2)











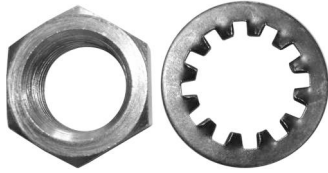

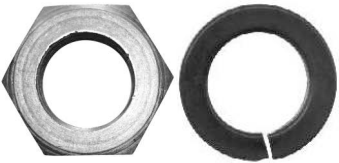
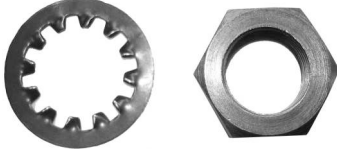
T7227
TRILOBULAR PORTAESCOBILLA
ALTERNADOR TIPO INDIEL
(CANT. 6 - 4 CORTOS-2 LARGOS)



T7228
RETEN RULEMAN ALTERNADOR
TIPO INDIEL (CANT. 3)

TUERCAS DE ROTOR Y ARANDELAS

 <p>T9110 ALTERNADOR TIPO INDIEL, GAREF, ARGELITE, BOSCH, CON ARANDELA ESTRELLA M17X1.25MM.</p>	 <p>T9160 ALTERNADOR TIPO NASHVILLE, BOSCH 55/70A. M14X22MM.</p>	 <p>T9161 ALTERNADOR TIPO BOSCH VARIOS M16X1.5MM.</p>	 <p>T9162 ALTERNADOR TIPO BOSCH 24V. 105/125A. M24X1.5MM.</p>
 <p>T9165 ALTERNADOR TIPO BOSCH, WAPSA 75A. M17X1.25MM.</p>	 <p>T9165E ALTERNADOR TIPO BOSCH, WAPSA 24V. 75A. (30MM. ENTRE CARAS)</p>	 <p>T9166 ALTERNADOR TIPO MARELLI, BOSCH VARIOS M17X1.5MM.</p>	 <p>T9169 ALTERNADOR TIPO NASHVILLE 125A. M20X30MM.</p>
 <p>T9170 ALTERNADOR TIPO BOSCH VOLVO 125A. M27X1,50MM.</p>	 <p>A5011 ARANDELAS ESTRELLA DE PRESION DE EJE (CANT. 10)</p>	 <p>A5012 ARANDELA DEPRESION EJE 16MM. (CANT. 10)</p>	 <p>A5014 ARANDELA ESTRELLA EJE 20MM. (CANT. 10)</p>

TAPAS PORTAESCOBILLAS DE DINAMO



701040
TAPA PORTA CARBON DE
DINAMO M. BENZ 608/1112/1114

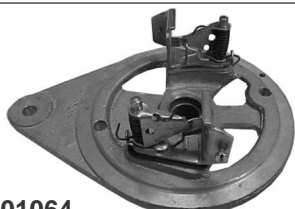

701064
TAPA PORTA CARBON DE DINAMO
CHEVROLET, IKA, ESTANCIERA



P4085
GATILLOS DINAMO IKA TIPO INDIEL

TAPAS PORTARULEMAN DE DINAMO



701020
FIAT 1500

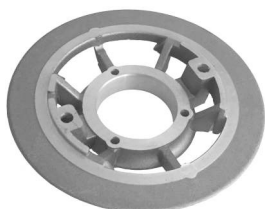

701022
FIAT 600/770/800/1100



701023
FIAT 600/770/800/1100



701025
CITROEN 2CV

ESPACIADORES DE DINAMO



E3063
ESPACIADOR FIAT 600 DINAMO
Ø20X5MM. EJE 12MM.



E3071
ESPACIADOR DINAMO FIAT 1500
Ø22X6.4MM. EJE 15MM.

POLEAS DE DINAMO



D1062
ESPACIADOR FIAT 600 DINAMO
Ø20X5MM. EJE 12MM.



D1068
FIAT 600 TODOS

RESORTES DE DINAMO



R1004
PORTAESCOBILLAS DINAMO
TIPO BOSCH (CANT. 4)



R1007
PORTAESCOBILLAS DINAMO
F.600/1100 (CANT. 2)



R1011
PORTAESCOBILLAS DINAMO
FORD, PEUGEOT (CANT. 2)



R1012
PORTAESCOBILLAS DINAMO
TIPO LUCAS (CANT. 2)



R1015
PORTAESCOBILLAS DINAMO
RENAUL, PEUGEOT (CANT. 2)



R1016
PORTAESCOBILLAS DINAMO
FIAT 1500 (CANT. 2)



R1017
PORTAESCOBILLAS DINAMO
TIPO TAMATEL (CANT. 2)



R1019
PORTAESCOBILLAS DINAMO
TIPO TAMATEL (CANT. 2)

TORNILLOS

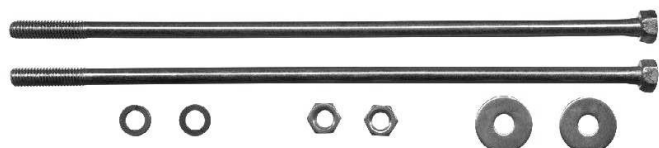

T8195
TORNILLOS PASANTES DINAMO FIAT 600 M5X163MM.
(CANT. 2)

RULEMANES



RU6000
RULEMAN 6000 DDU



RU6001
RULEMAN 6001 DDU



RU6002
RULEMAN 6002 DDU



RU6003
RULEMAN 6003 DDU



RU608
RULEMAN 608 DDMC3



RU6200
RULEMAN 6200 DDU



RU6201
RULEMAN 6201 DDU



RU6202
RULEMAN 6202 DDU



RU6203
RULEMAN 6203 DDU



RU6204
RULEMAN 6204 DDU



RU6205
RULEMAN 6205 DDU



RU62201
RULEMAN 62201 DDUC3E



RU63001
RULEMAN 63001 DDUC3E



RU6301
RULEMAN 6301 DDU



RU6302
RULEMAN 6302 DDU



RU6303
RULEMAN 6303 DDU









RUB17-102
RULEMAN B17-102A-A-1T1X-01
BC MA7C1

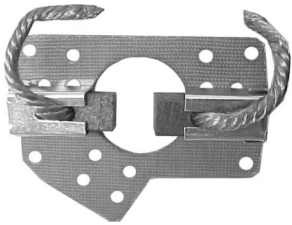
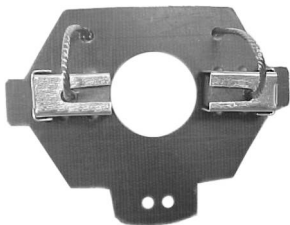
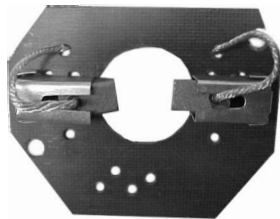
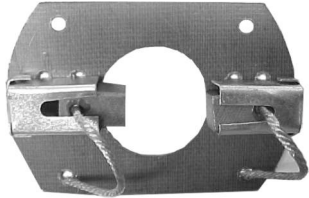
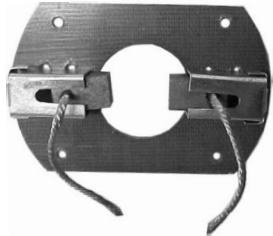
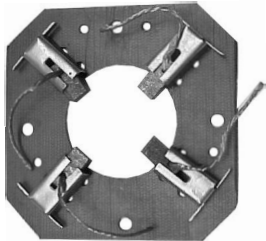

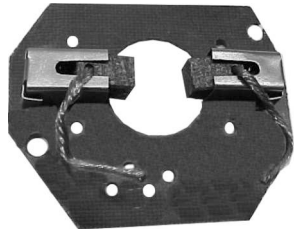
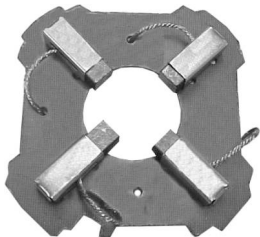
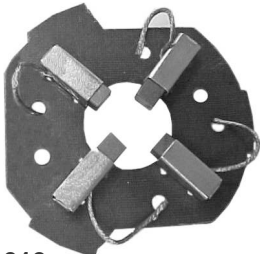
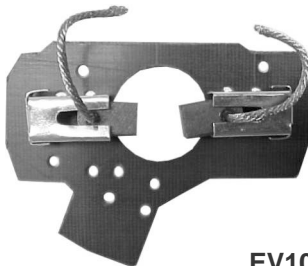
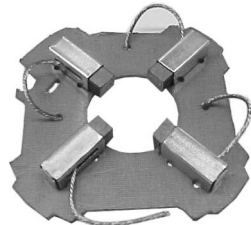
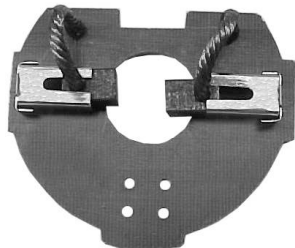
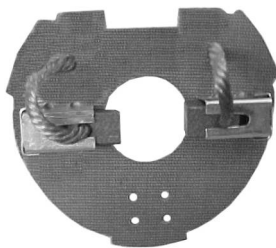
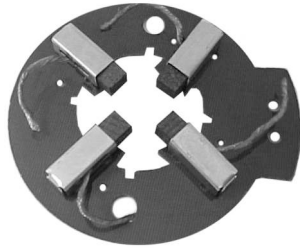
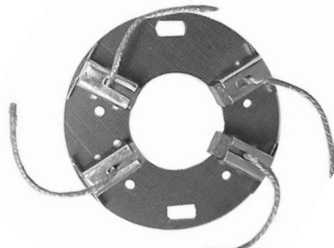
RUB17-126
RULEMAN B17-126 DDWC3

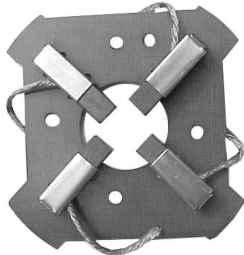
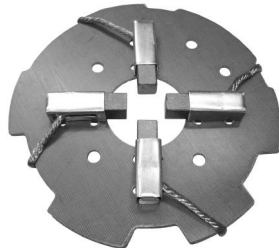
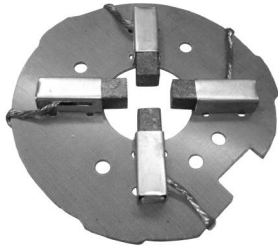
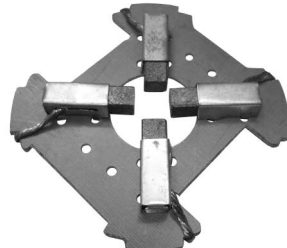
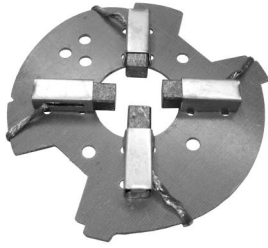
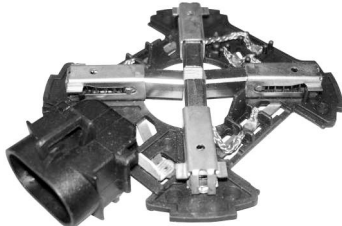
PORTAESCOBILLAS ELECTROVENTILADOR

 <p>EV1001 TEG MODELO NUEVO COMPLETO</p>	 <p>EV1003 TEG MODELO VIEJO COMPLETO</p>	 <p>EV1004 FIAT 128 - M. MARELLI</p>	 <p>EV1005 FIAT 128 - NORMAN</p>
 <p>EV1006 FIAT 125 / 128 - TEG MOD. VIEJO</p>	 <p>EV1007 FIAT 125, RENAULT 12/18 TEG</p>	 <p>EV1016 BOSCH</p>	 <p>EV1017 M. MARELLI</p>
 <p>EV1018 FAT</p>	 <p>EV1019 FAT</p>	 <p>EV1020 BRIEVA M/N</p>	 <p>EV1021 MARCHAL FRANCES</p>
 <p>EV1022 WAPSA SIN AIRE</p>	 <p>EV1023 FAT SIN AIRE</p>	 <p>EV1025 FIAT 147 FAT</p>	 <p>EV1026 FORD ESCORT MODELO NUEVO</p>
 <p>EV1027 VALEO PEUGEOT 405 - 505</p>	 <p>EV1029 FAT GRANDE</p>	 <p>EV1030 MONDEO - SIEMENS</p>	 <p>EV1033 CHEVROLET VECTRA - BOSCH</p>
 <p>EV1034 PEUGEOT 206</p>	 <p>EV1035 MAREA</p>	 <p>EV1036 ORIGINAL GATE</p>	 <p>EV1037 TIPO GATE ORIGINAL SIN FICHA</p>

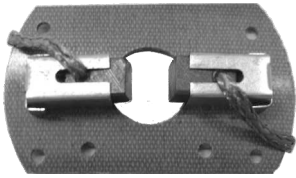
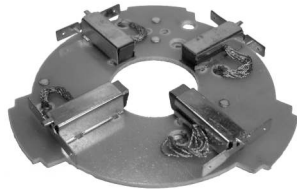
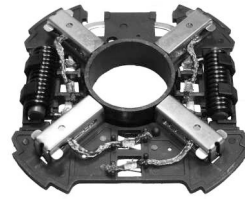
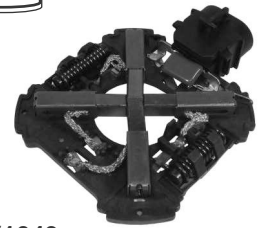
PORTAESCOBILLAS ELECTROVENTILADOR

EV1038
M. MARELLI AGUJERO CHICO

EV1039
CON PUENTES 7X7X18

EV1042
7X8X19 SIN FICHA

EV1043
RENAULT, PEUGEOT, FIAT,
FORD, CHEVROLET

EV1044
RENAULT, PEUGEOT, FIAT, FORD

EV1045
RENAULT19

EV1046
FIAT PALIO

EV1047
FIATUNO-DIESEL, DUNA-NAFTA

EV1048
PEUGEOT405

EV1049
6X10X18

BUJE Y PORTABUJE

EV1008
TEG - FIAT 125 / 128 (9,5mm.)

EV1009
TEG - FIAT 125 / 128 (10mm.)

EV1010
TEG - FIAT 128 (12mm.)

EV1011
FIAT 128 NORMAN

EV1031
R19 8MM. BOSCH

EV1032
BR19 10MM. BOSCH

EV1041
ECTA FRANCES

TAPAS

EV1012
TEG - FIAT 128 MODELO VIEJO

VARIOS



EV1002
JUEGO TRABA CIERRE MOTOR
TEG OPEL BRIEVA



EV1024
CABLE ELECTROVENTILADOR
PEUGEOT



EV5039
TUERCA ROSCA IZQUIERDA
RENAULT 18



EV5040
TUERCA ROSCA IZQUIERDA
PEUGEOT 405, POLO, ETC.



EV1800
TRABA DE ELECTROVENTILADOR
PARA EJE 10MM.

EV1800/8
TRABA DE ELECTROVENTILADOR
PARA EJE 8MM.

PORTAESCOBILLAS DE CALEFACTOR

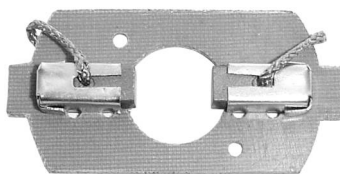

CN1002
NORMAN

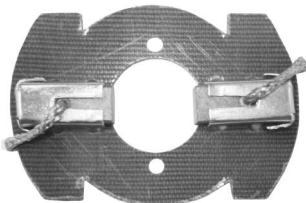

CN1006
R4/R12/TAUNUS

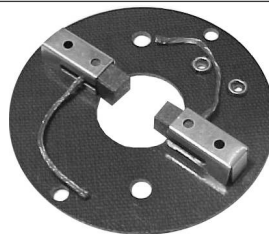

CN1007
M. BENZ - PLASTICO

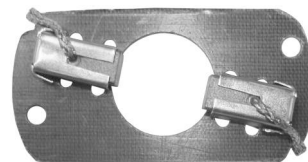

CN1008
UNIVERSAL

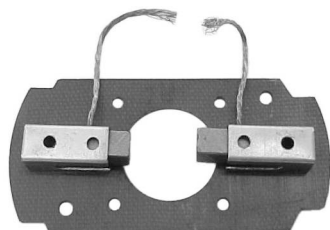

CN1009
FALCON, M. BENZ

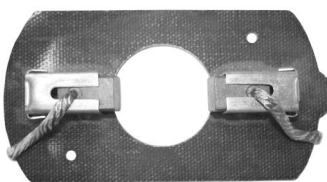

CN1011
ROCKET

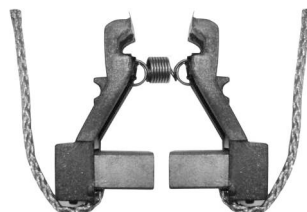

CN1020
TEG



CN1023
M. BENZ MOTOR PLASTICO



CN1024
FORD NIPPONNIPPONDENSO

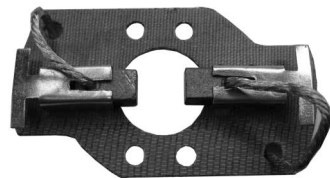

CN1025
FORD - DOBLE TURBINA

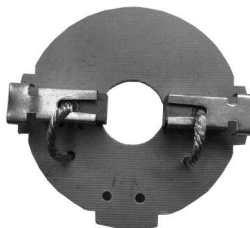

CN1026
FORD FIESTA BOSCH



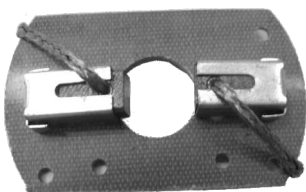

CN1027
RENAULT MEGANE-TRANSIT ETC.



CN1028
T. NORMAN MODELO NUEVO

BUJE Y PORTABUJE

 <p>CN1005 REPARACION COMPLETA TAPA CALEFACTOR NORMAN</p>	 <p>Cn1010 TEG</p>	 <p>CN1012 PEUGEOT 505, R12, GACEL</p>	 <p>Cn1013 ROCKET</p>
--	--	---	---

 <p>CN1021 NORMAN</p>	VARIOS CALEFACTOR		
---	--------------------------	--	--

 <p>CN1003 SOPORTE PORTAESCOBILLAS CALEFACTOR NORMAN</p>	 <p>CN1004 TORNILLO MOTOR CALEFACTOR NORMAN</p>	 <p>CN1022 JUEGO ENGRANAJES CAJA EVAPORADORA P405, R19</p>
---	---	---

 <p>CN1029 RETEN DE GOMA CALEFACTOR ROCKET</p>	ESTRIAS LIMPIAPARABRISAS		
--	---------------------------------	--	--

 <p>EL1540 CHEVROLET AGUJEROS CHICO (CANT. 2)</p>	 <p>EL1541 CHEVROLET AGUJEROS MEDIANO (CANT. 2)</p>	 <p>EL1542 CHEVROLET AGUJEROS GRANDE (CANT. 2)</p>	 <p>EI1543 OPEL K 180 (CANT. 2)</p>
---	---	---	---

 <p>EI1544 RENAULT 4S - JEEP IKA (CANT. 2)</p>	 <p>EL1545 BRAZO PEUGEOT 403 (CANT. 2)</p>	 <p>EL1546 BRAZO RENAULT 4 - PEUGEOT 404 (CANT. 2)</p>	 <p>EL1547 LIMPIAPARABRISASMOPAR (CANT.2)</p>
--	--	---	---

ESTRIAS LIMPIAPARABRISAS



EL1548
LIMPIAPARABRISAS FIAT 600/125,
RENAULT 6/12, PEUGEOT 504,
CITROEN (CANT. 2)



EL1548A
FALCON UNIVERSAL (CANT. 2)



EL1549
LIMPIAPARABRISAS FORD
FALCON, FIAT 128 UNIVERSAL
(CANT. 2)



EL1549A
SOPORTE BRAZO FORD TAUNUS
(CANT. 2)



EL1679
LUNETAS DODGE 1500,
RENAULT 11, ETC. (CANT. 1)

MOTOR DE ALTA Y BAJA

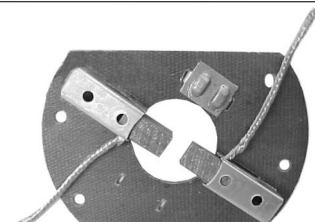

MAB1001
PORTAESCOBILLAS ALTA Y BAJA
TIPO ROHER



MAB1005
GOMA DE ACOPLE DE MOTOR
ALTA Y BAJA

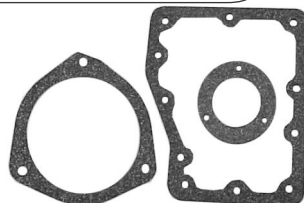

MAB1006
JUEGO DE JUNTAS MOTOR ALTA
Y BAJA

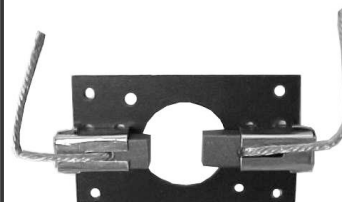

MAB1007
PORTAESCOBILLAS ALTA Y BAJA
EATON

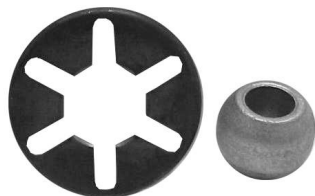

MAB1008
PORTA BUJE Y BUJE DE ALTA Y
BAJA

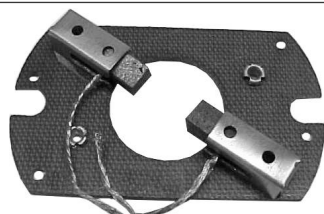

MAB1009
PORTAESCOBILLAS ALTA Y BAJA
CANADIENSE



MAB1011
ENGRANAJE ALTA Y BAJA

MOVIMIENTOS COMPLETOS



ML1000
SILVERADO 2000

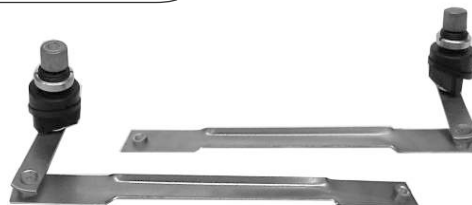

MI1001
FORD 600, PICK UP F100 63/67

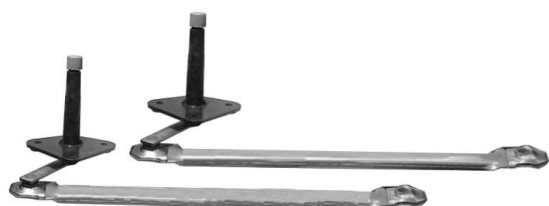

ML1002
PICK UP F100 - 68 / 73

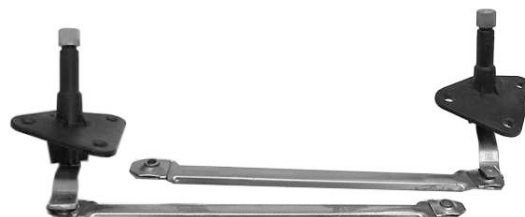

ML1003
PICK UP F100 - 73 / 81

MOVIMIENTOS COMPLETOS

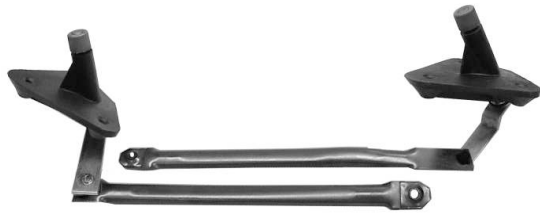

ML1004
PICK UP F100 - 81 / 92

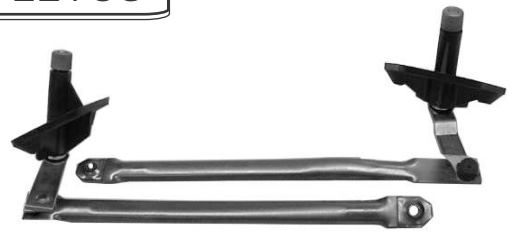

ML1005
PICK UP F100 1992 EN ADELANTE



ML1006
FORD HASTA 91, RANCHERO 75 AL 82



ML1007
FORD FALCON DESDE 1992 EN ADELANTE



ML1008
DODGE PICK UP M/VIEJO



ML1009
PICK UP Y CAMION DODGE MODELO NUEVO



ML1010
PICK UP CHEVROLET C10 SILVERADO 87 EN ADELANTE



ML1011
CHEVROLET 400



ML1012
CHEVROLET BRAVA 67



ML1013
CHEVROLET BRAVA MODELO NUEVO



ML1014
PICK UP CHEVROLET APACHE



ML1015
CHEVROLET CHEVY

MOVIMIENTOS COMPLETOS



ML1017
TORINO MODELO VIEJO



ML1020
M. BENZ 1112 / 1114

ML1017D
TORINO MODELO NUEVO



ML1021
MERCEDES BENZ 1112 - REFORMA



ML1022
M. BENZ 1517



ML1023
MERCEDES BENZ 608 - MODELO VIEJO



ML1024
MERCEDES BENZ 608 - MODELO NUEVO



ML1025
FORD TAUNUS - MODELO VIEJO



ML1026
M. BENZ 1214/1215



ML1027
FORD TAUNUS MODELO NUEVO



ML1028
PEUGEOT 504 MODELO NUEVO



ML1029
PEUGEOT 504 MODELO VIEJO



ML1031
MERCEDES 608/1114/1517/1521 - 3 BRAZOS MODELO NUEVO

MOVIMIENTOS COMPLETOS



ML1032
FIAT 619 CAMION 3 BRAZOS



ML1033
SILVERADO MODELO VIEJO



ML1034
M. BENZ 1632/1633

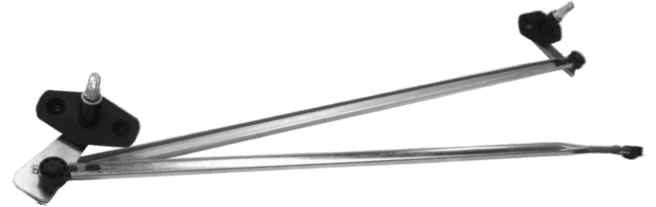

ML1035
ISUZU LUV

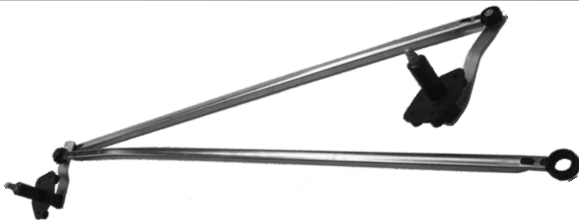

ML1600
CHEVROLET D 20



ML1601
MERCEDES BENZ 180



ML2001
RANGER TODOS

ML2002
PICK UP F100 92 EN ADELANTE CON BOLITA



ML2003
UNIMOG

PIVOTES



PL1091
FORD F100 63/68



PL1092
FALCON MODELO VIEJO
C/ESTRIAS





















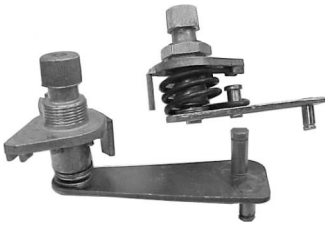
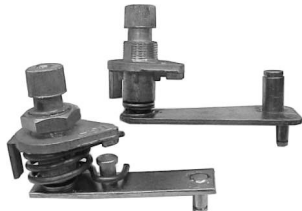



PL1093
FALCON MODELO NUEVO
C/TUERCA)

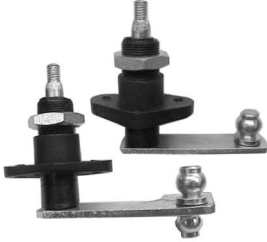



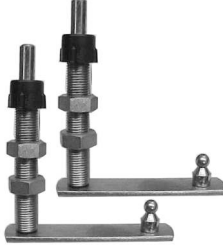











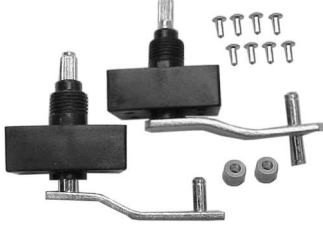



PL1094
PICK UP DODGE Y CAMION
MODELO VIEJO

PIVOTES

 <p>PL1095 PICKUP DODGE Y CAMION MODELO NUEVO</p>	 <p>PL1096 DODGE 1500 MODELO NUEVO</p>	 <p>PL1097 GOL, SENDA, GACEL, SAVEIRO</p>	 <p>PL1098 CHEVROLET 400 SIMPLE</p>
 <p>PL1099 CHEVROLET 400 DOBLE</p>	 <p>PL1100 CHEVY</p>	 <p>PL1101 PICK UP CHEVROLET APACHE</p>	 <p>PL1102 PICKUP CHEVROLET BRAVA 67/73</p>
 <p>PL1103 PICKUP CHEVROLET 74 EN ADELANTE</p>	 <p>PL1104 PICKUP CHEVROLET SILVERADO</p>	 <p>PL1105 TORINO</p>	 <p>PL1106 TORINO MODELO VIEJO C/PERNO GRUESO</p>
 <p>PL1110 RENAULT 4L/4S</p>	 <p>PL1111 RENAULT 6</p>	 <p>PL1112 RENAULT 12TS/TE</p>	 <p>PL1113 RENAULT 12TSTIPOBUFFALO</p>
 <p>PL1114 RENAULT 12 MODELO NUEVO, DACIA</p>	 <p>PL1115 RENAULT 18 TIPOTEGC/BOLITA</p>	 <p>PL1116 RENAULT 18 TIPOBUFAFOC/PERNO</p>	 <p>PL1117 CITROEN 2CV/3CV</p>
 <p>PL1118 CITROEN AMI 8</p>	 <p>PL1119 M. BENZ 1112</p>	 <p>PL1120 M. BENZ 1517</p>	 <p>PL1121 PEUGEOT 404 MODELO VIEJO</p>

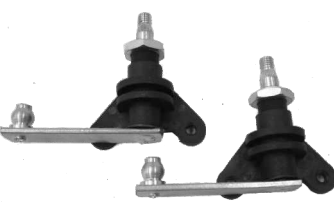









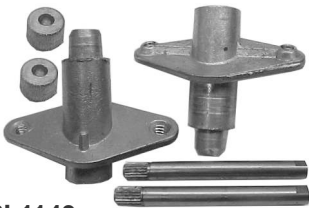

PIVOTES

 <p>PL1122 PEUGEOT 404 MODELO NUEVO</p>	 <p>PL1123 PEUGEOT 504</p>	 <p>PL1123N PEUGEOT 504 MODELO NUEVO</p>	 <p>PL1124 PEUGEOT LADO MOTOR</p>
 <p>PL1125 FIAT 128 TIPO BRIEVA</p>	 <p>PL1126 FIAT 125 TIPO BRIEVA</p>	 <p>PL1127 FIAT 125 TIPO TEG</p>	 <p>PL1128 FIAT 147</p>
 <p>PL1129 FIAT CAMION MODELO VIEJO</p>	 <p>PL1130 FORD TAUNUS</p>	 <p>PL1131 MERCEDES BENZ 1214 / 1215</p>	 <p>PL1134 COMPLETO DUNA/UNO TIPO BOSCH, ISACO</p>
 <p>PL1135 M. BENZ 608 MODELO VIEJO</p>	 <p>PL1136 M. BENZ 608 MODELO NUEVO</p>	 <p>PL1137 M. BENZ 1517 3 BRAZOS</p>	 <p>PL1138 M. BENZ 1112 REFORMA</p>
 <p>PL1139 M. BENZ 1632 / 1633</p>	 <p>PL1140 FIAT REGATTA</p>	 <p>PL1141 TRAFIC TODOS</p>	 <p>PL1142 SILVERADO 2000</p>
 <p>PL1143 SILVERADO 1999</p>			

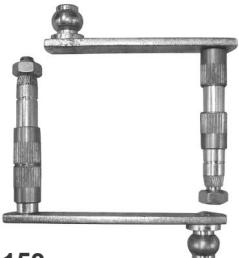

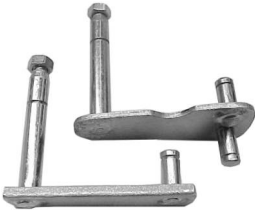

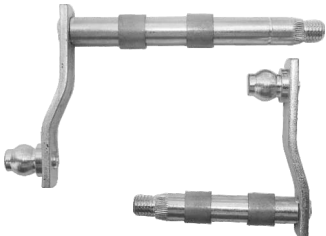



EJES

 <p>PL1086 RENAULT 12 MODELO VIEJO C/ESTRIA</p>	 <p>PL1087 PEUGEOT 504</p>	 <p>PL1194 PEUGEOT 504 MODELO NUEVO C/BUJE Y ROSCA</p>	 <p>PL1195 DUNA, UNO TODOS</p>
---	--	---	--

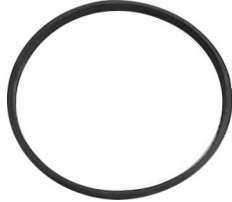
PIVOTES REPARACION









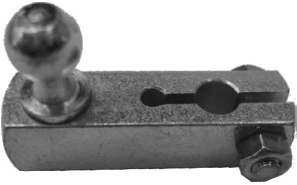

 <p>PL1146 JUEGO FORD FALCON MODELO VIEJO</p>	 <p>PL1147 JUEGO FORD FALCON MODELO NUEVO</p>	 <p>PL1148 JUEGO DODGE 1500</p>	 <p>PL1149 JUEGO CHEVROLET PICK UP APACHE</p>
 <p>PL1150 JUEGO CHEVROLET BRAVA 67/73</p>	 <p>PL1151 JUEGO CHEVROLET BRAVA 67/73</p>	 <p>PL1152 JUEGO R12 C/BUJE (PERNO)</p>	 <p>PL1152B JUEGO R12 EJE Y BIELAS TIPO TEG (BOLITA)</p>
 <p>PL1153 JUEGO R11/9 C/BUJE YBIELAS</p>	 <p>PL1154 JUEGO FIAT 600 PICO FINO C/TUERCA</p>	 <p>PL1155 JUEGO FIAT 600 PICO GRUESO C/TUERCA</p>	 <p>PL1156 JUEGO FIAT 600 C/ESTRIAS</p>
 <p>PL1157 JUEGO PALIO, SIENA</p>	 <p>PL1158 JUEGO DUNA, UNO TIPO BOSCH/ISACO</p>	 <p>PL1185 REPARACION DE BRAZOS- UNIVERSAL</p>	

JUNTAS Y TRABAS

 <p>LP1226 TOPE VARILLAJE PIVOTE DUNA (2 UNIDADES)</p>	 <p>PL1186 JUNTA DE PIVOTE RENAULT</p>	 <p>PL1187 JUNTA DE PIVOTE FORD</p>	 <p>PL1188 JTA.DE FLOTANTE FORD FALCON</p>
 <p>PL1189 GUARDAPOLVO DODGE 1500</p>	 <p>VL1020 TRABA AGUJERO CHICO</p>	 <p>VL1021 TRABA AGUJERO MEDIANO</p>	 <p>VL1022 TRABA AGUJERO GRANDE</p>
 <p>VL1023 TRABA AGUJERO CHICO EN U</p>	<div data-bbox="726 1097 885 1164" data-label="Section-Header"> <p>LEVAS</p> </div>		

 <p>PL1300 PICKUP DOGE 100, LADO MOTOR CORTA</p>	 <p>PL1301 PICKUP DOGE 100 LADO MOTOR LARGA</p>	 <p>PL1302 M. BENZ 114 / 1517 CORTA</p>	
 <p>PL1303 M. BENZ 1114 / 1517 LARGA</p>	 <p>PL1304 M.BENZ 608/3 BRAZOS MOTOR</p>	 <p>PL1305 TORINO LADO MOTOR MODELO NUEVO</p>	 <p>PL1307 FIAT 619 CAMION</p>
 <p>PL1308 M.BENZ 1215/1632/1633</p>	 <p>PL1309 FALCON C/CUADRANTE RECTO Y PERNO</p>	 <p>PL1310 FALCON C/CUADRANTE REDONDO Y PERNO</p>	 <p>PL1311 FALCON C/CUADRANTE RECTIPO Y BOLITA</p>

LEVAS

 <p>PL1313 M. BENZ 608 MODELO VIEJO</p>	 <p>PL1314 M. BENZ 608 MODELO VIEJO</p>	 <p>PL1316 FIAT 147 TODOS</p>	 <p>PL1317 RENAULT 11/9 TODOS</p>
 <p>PL1318 PEUGEOT 405 TODOS</p>	 <p>PL1320 F100</p>	 <p>PL1321A CHEVROLET APACHE LARGA</p>	 <p>PL1322 SILVERADO</p>
 <p>PL1323 BRAVA 67</p>	 <p>PL1326 CHEVROLET 74</p>	 <p>PL1328 F10074AL81,FORD7000</p>	

PUNTAS VARILLAS

 <p>VI1001 PEUGEOT 505, RENAULT 11/9/18/19, GOL, SENDA</p>	 <p>VL1002 PEUGEOT 504, RENAULT 6/12/18 Ø6</p>	 <p>VL1003 SIERRA, GOL, FIAT 619 Ø16</p>	 <p>VL1004 PEUGEOT 505, SIERRA, ESCORT BUFFALO Ø12</p>
 <p>VL1005 FIAT 600/147/128/125, DODGE Ø8</p>	 <p>VL1006 DODGE PIK UP, RENAULT12 TEG Ø6</p>	 <p>VL1007 RENAULT 9/11, CIEGA BUFALO Ø9,5</p>	 <p>VL1008 RENAULT 6/12/18, CITROEN, PEUGEOT 504 TEG Ø6</p>
 <p>VI1009 FORD ORION, VW POINTER Ø13</p>	 <p>VL1010 MEGANE, SURAN, LUV, ISUZU</p>		

VARILLAS

 <p>VL1036 FFORD F100 63/68 - LARGO 28,5CM.</p>	 <p>VL1037 FORD SIERRA CORTA - LARGO 40CM.</p> <p>VI1038 FORD SIERRA CORTA - LARGO 40CM.</p>	
 <p>VL1039 FORD FIESTA CORTA - LARGO 26CM.</p>	 <p>VL1039L FORD FIESTA LARGA - LARGO 27,5CM.</p>	 <p>VI1040 FORD TAUNUS CORTA - LARGO 39,5CM.</p> <p>VL1040L FORD TAUNUS LARGA - LARGO 57CM.</p>
 <p>VL1041 FORD ORION CORTA - LARGO 27CM.</p>	 <p>VL1041L FORD ORION LARGA - LARGO 28CM.</p> <p>VL1042 PICK UP DODGE 100 CORTA - LARGO 50,3CM.</p>	

VARILLAS



VL1043
PICK UP DODGE 1000 CORTA -
LARGO 22,5CM.



VL1044
DODGE 1500 - LARGO 27,8CM.



VL1045
VOLKSWAGEN GOL
MODELO VIEJO CORTA -
LARGO 20,8CM.

VL1045L
VOLKSWAGEN GOL
MODELO VIEJO LARGA -
LARGO 36CM.



VL1045G
VOLKSWAGEN GOL 95 CORTA CON PUNTERAS GRANDES -
LARGO 21CM.



VL1045GL
VOLKSWAGEN GOL 95 LARGA CON PUNTERAS IGUALES -
LARGO 36CM.



VL1046
VOLKSWAGEN GOL MODELO
NUEVO CORTA - LARGO 28CM.

VL1046L
VOLKSWAGEN GOL MODELO
NUEVO LARGA - LARGO 28CM.



VL1047
SENDA, GACEL CORTA -
LARGO 20,5CM.

VL1047L
SENDA, GACEL LARGA -
LARGO 35,5CM.



VL1048
CARAT CORTA -
LARGO 33CM.

VL1048L
CARAT LARGA -
LARGO 53CM.



VL1049
FIAT REGATTA CORTA -
LARGO 18,5CM.

VL1049L
FIAT REGATTA LARGA -
LARGO 50,5CM.



VL1050
FIAT SIENA CORTA -
LARGO 12CM.

VL1050L
FIAT SIENA LARGA -
LARGO 37CM.



VL1051
RENAULT 6 MODELO
VIEJO CORTA -
LARGO 22,5CM.

VL1051L
IRENAULT 6 MODELO
VIEJO LARGA -
LARGO 27,5CM.



VL1052
RENAULT 6
MODELO NUEVO CORTA -
LARGO 22CM.

VL1052L
IRENAULT 6
MODELO NUEVO LARGA -
LARGO 30CM.

VARILLAS



VL1053
RENAULT CLIO VALEO (BOLITA)
CORTA - LARGO 26CM.

VL1053L
RENAULT CLIO VALEO (BOLITA)
LARGA - LARGO 30CM.



VI1054
RENAULT CLIO BUFFALO
(PERNO) CORTA - LARGO 16,5CM.

VL1054L
RENAULT CLIO BUFFALO
(PERNO) LARGA - LARGO 38CM.



VL1055
RENAULT 19 VALEO (BOLITA)
CORTA - LARGO 17CM.

VL1055L
RENAULT 19 VALEO (BOLITA)
LARGA - LARGO 58CM.



VL1056
RENAULT 18 TEG CORTA
(BOLITA)-LARGO 15CM.

VL1057
RENAULT 18 TEG LARGA
(BOLITA) - LARGO 53,5CM.



VL1058
RENAULT COUPE FUEGO -
LARGO 15CM.



VL1059
RENAULT 18 BUFFALO CORTA
(PERNO) - LARGO 15CM.

VL1060
RENAULT 18 BUFFALO LARGA
(PERNO) - LARGO 54,5 CM.



VL1061
RENAULT 11 CORTA -
LARGO 29CM.

VL1061L
RENAULT 11 LARGA -
LARGO 31CM.



VL1062
RENAULT TRAFIC CORTA -
LARGO 51CM.

VL1062L
RENAULT TRAFIC LARGA -
LARGO 62CM.



VI1063
PEUGEOT 504 CORTA
(PERNO) - LARGO 32,5CM.

VI1064
PEUGEOT 504 LARGA
(PERNO) - LARGO 62,5CM.



VL1065
PEUGEOT 505 CORTA NACIONAL
(PERNO) - LARGO 31CM.

VL1066
PEUGEOT 505 LARGA NACIONAL
(PERNO) - LARGO 62 CM.



VL1067
PEUGEOT 505
CORTA IMPORTADA
(BOLITA) - LARGO 31CM.

VL1068
PEUGEOT 505
LARGA IMPORTADA
(BOLITA) - LARGO 63CM.



VL1069
PEUGEOT 405 CORTA
(BOLITA) - LARGO 22CM.

VL1070
PEUGEOT 405 LARGA
(BOLITA) - LARGO 46,5CM.

VARILLAS



VL1071
PEUGEOT 405 LARGA
(BOLITA) - LARGO 46,5CM.

VL1071L
FIAT CAMION MODELO NUEVO
LARGA - LARGO 84,5CM.



VL1072
FIAT 147 TODOS CORTA -
LARGO 21CM.

VL1072L
FIAT 147/FIORINO LARGA -
LARGO 43,5CM.



VL1073
FIAT CAMION MODELO VIEJO - LARGOS: 43/50,5/52CM.

A: 43 cm
B: 50,5 cm
C: 52 cm



VL1074
M. BENZ 1517 MODELO NUEVO
CORTA - LARGO 40CM.

VL1074L
M. BENZ 1517 MODELO NUEVO
LARGA - LARGO 50CM.



VL1076
LADO MOTOR TORINO MODELO NUEVO - LARGO 39CM.



VL1077
FIAT TIPO CORTA -
LARGO 17CM.

VL1078
FIAT TIPO LARGA -
LARGO 38,5CM.



VL1079
FORD GALAXY CORTA -
LARGO 33CM.



VL1081
ESCORT MODELO VIEJO
CORTA - LARGO 21,5CM.

VL1082
ESCORT MODELO VIEJO
LARGA - LARGO 49CM.



VL1083
CHEVROLET MONZA
CORTA - LARGO 29,5CM.

VL1084
CHEVROLET MONZA
LARGA - LARGO 55CM.



VL1085
VOLKSWAGEN GOL 99/2000 CORTA - LARGO 29CM.



VL1086
VOLKSWAGEN GOL 99/2000 PUNTAS DESIGUALES - LARGO 29CM.

VARILLAS



VL1087
FIAT DUCATO CORTA -
LARGO 60CM.



VL1089
RENAULT 21 CORTA -
LARGO 48CM.

VL1088
FIAT DUCATO LARGA -
LARGO 65CM.



VL1400
CHEVROLET CORSA CORTA -
LARGO 19,5CM.



VL1402
MONOBRAZO M. BENZ - LARGO 10CM.

VL1401
CHEVROLET CORSA LARGA -
LARGO 26CM.



VL1403
MONOBRAZO M. BENZ - LARGO 13CM.

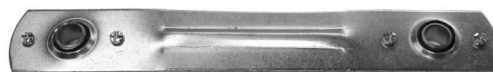

VL1404
MONOBRAZO M. BENZ - LARGO 15CM.



VL1407
RENAULT 12 BUFFALO CORTA
(BOLITA) - LARGO 27,4CM.



VL1409
VOLKSWAGEN CADDY LUNETA - LARGO 10,6CM.

VL1408
RENAULT 12 BUFFALO LARGA
(BOLITA) - LARGO 30,3CM.



VL1412
POLO CLASIC 99 CORTA -
LARGO 22,3CM.



VL1415
CHEVROLET LUV LARGA -
LARGO 59CM.

VL1413
POLO CLASIC 99 LARGA -
LARGO 31,6CM

VARILLAS



VL1418
RENAULT 12 TEG CORTA
(PERNO) - LARGO 27,7CM.



VL1419
RENAULT 12 TEG LARGA
(PERNO) - LARGO 30,3CM.

VL1420
FIAT 125 CORTA -
LARGO 15,5CM.

VL1421
FIAT 125 LARGA -
LARGO 40CM.



VL1422
FIAT 600 CORTA -
LARGO 31CM.



VL1423
FIAT 600 LARGA -
LARGO 38CM.

VL1424
FORD KA CORTA -
LARGO 22,5CM.

VL1425
FORD KA LARGA -
LARGO 22,6CM.



VL1426
PEUGEOT 306 CORTA -
LARGO 20,3CM.



VL1427
PEUGEOT 306 LARGA -
LARGO 25,8CM.

VL1428
RENAULT KANGOO CORTA
VALEO - LARGO 27,8CM.

VL1429
RENAULT KANGOO LARGA
VALEO - LARGO 28,9CM.



VL1430
DAEWOO CORTA -
LARGO 25,7CM.

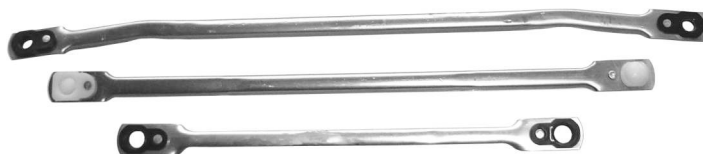

VL1431
DAEWOO LARGA -
LARGO 25,7CM.

VL1432
SCANIA 913 - LARGOS 34,5/37,5/57CM.



VL1433
M. BENZ 1215 CORTA -
LARGO 54CM.



VL1434
M. BENZ 1215 LARGA -
LARGO 77,8CM.



VL1435
M. BENZ 1632/1633 CORTA -
LARGO 54,4CM.

VL1436
M. BENZ 1632/1633 LARGA -
LARGO 77,5 CM.



VL1437
FIAT 128 CORTA -
LARGO 18,9CM.

VL1438
FIAT 128 LARGA -
LARGO 45,7CM.

VARILLAS



VL1439
FIAT 147 BRIO CORTA - LARGO 20,2CM.



VL1440
FIAT 147 BRIO LARGA - LARGO 20,3CM.



VL1441
PEUGEOT 206 CON SOPORTE FIJACION IGUAL - LARGO 19,8CM.



VL1442
PEUGEOT 206 CON SOPORTE FIJACION DESIGUAL - LARGO 19,5CM.



VL1443
RENAULT MEGANE CORTA - LARGO 45CM.



VL1444
RENAULT MEGANE LARGA - LARGO 59CM.



VL1445
VOLKSWAGEN GOLF CORTA - LARGO 45,5CM.



VL1446
VOLKSWAGEN GOLF LARGA - LARGO 55,5CM.



VL1447
RENAULT EXPRESS CORTA - LARGO 29,2CM.



VL1448
RENAULT EXPRESS LARGA - LARGO 31,2CM.



VL1449
PARTNER, BERLINGO CORTA - LARGO 45,2CM.

VL1450
PARTNER, BERLINGO LARGA - LARGO 51,4CM.



VL1451
FIAT TEMPRA CORTA - LARGO 17CM.

VL1452
FIAT TEMPRA LARGA - LARGO 38,6CM.

VARILLAS



VL1453
HILUX CORTA - LARGO 51,5 CM.

VL1454
HILUX LARGA -
LARGO 61 CM.



VL1455
ECOSPORTCORTA-LARGO21CM.

VL1456
ECOSPORT LARGA-
LARGO 33,5CM.



VL1457
FORD FOCUS CORTA - LARGO 45,5 CM

VL1458
FORD FOCUS LARGA -
LARGO 59 CM.

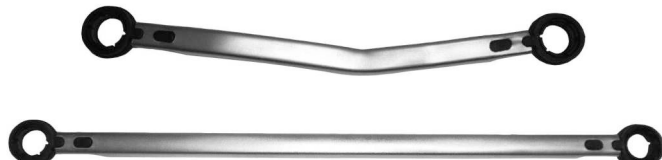

VL1459
CORTA RENAULT SCENIC

VL1460
LARGA RENAULT SCENIC



VL1461
SURAN CORTA

VL1462
SURAN LARGA



VL1463
PEUGEOT 106 CORTA - LARGO 20.9 MM.



VL1464
PEUGEOT 106 LARTA - LARGO 26 MM.



VL1465
MERIVA MEDIANA



VL1466
MERIVA MEDIANA



VL1467
MERIVA LARGA







VL1468
AMAROK CORTA

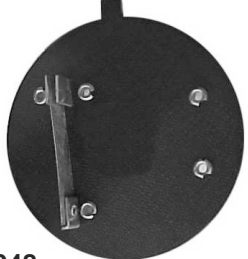

VL1469
AMAROK LARGA

AUTOMÁTICOS DE PARE

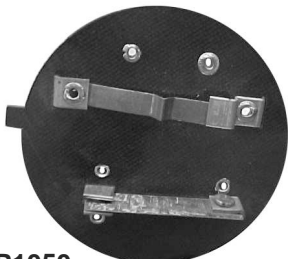

 <p>LP1022 PEUGEOT 404 - BRIEVA</p>	 <p>LP1023 M. BENZ - BRIEVA</p>	 <p>LP1025 FORD FALCON 70/80 - BRIEVA</p>	 <p>LP1027 M. BENZ C/CABLE - BRIEVA</p>
---	---	--	---

 <p>LP1043 PICK UP DODGE / VALIANT</p>	 <p>LP1045 LINEA FORD S/CABLE</p>	 <p>LP1046 AUTOMATIDO DE PARE CHEVROLET 69/73 - BRIEVA</p>	 <p>LP1047 CHEVROLET TODOS - BRIEVA</p>
--	---	---	---

 <p>LP1048 FIAT 125 - BRIEVA</p>	 <p>LP1049 FIAT 128/PEUGEOT 504 - BRIEVA</p>	 <p>LP1050 CHEVY 74 - BRIEVA</p>	 <p>LP1191 PEUGEOT 504 DERECHO - BUBALO/VALEO DERECHO</p>
---	---	--	--

 <p>LP1192 RENAULT 19 IZQUIERDO - BUFFALO/VALEO</p>	 <p>LP1247 DODGE MOD. VIEJO IMPORTADO</p>		
---	---	--	--

BUJES Y PORTA BUJES

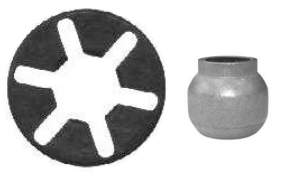
 <p>LP1028 FIAT 619</p>	 <p>LP1029 LIMPIAPARABRISAS FIAT CAMION</p>	 <p>LP1127 DODGE, VALIANT EJE 8.5MM.</p>	 <p>LP1128 FFORD LADO TAPA EJE 8.5MM.</p>
---	---	---	---

BUJES Y PORTA BUJES

LP1129
FORD LADO TAPA EJE 8.5MM.



LP1131
OPEL, FIAT LADO COLECT
EJE 8.5MM.



LP1135
BUFFALO MODELO NUEVO
ORIGINAL EJE 8MM.



LP1151
BUJE CAJA REDUCTORA
CHEVROLET - 11X16X10 MM.



LP1152
BUJE CAJA REDUCTORA M.
BENZ 11X16X13MM. - BRIEVA



LP1153
BUJE CAJA REDUCTORA FIAT
10X13X25MM. - TEG

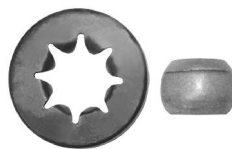

LP1224
FORD FALCON/F100 -
TIPO BRIEVA



LP1241
FIAT UNO/DUNA - ISACO/BOSCH

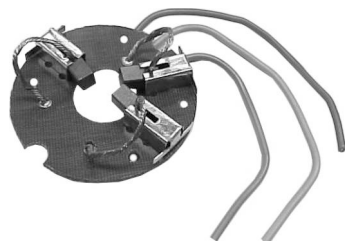

LP1256
HIDRAULICA KANGOO

PORTAESCOBILLAS

LP1003
PEUGEOT 504 - BRIEVA



LP1005
FIAT 125/128 - BRIEVA

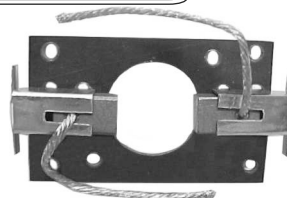

LP1006
CHEVROLET, PEUGEOT, DODGE,
ETC. - BRIEVA

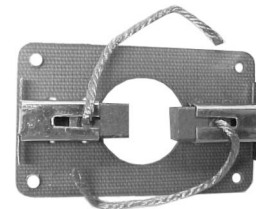

LP1008
FIAT 600/1500 1 VELOCIDAD -
TEG

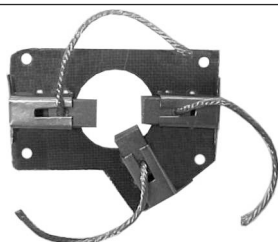

LP1009
TORINO, DODGE 1500 2
VELOCIDADES - TEG



LP1010
FORD TAUNUS - TEG



LP1011
RENAULT, PEUGEOT, CITROEN -
BUFFALO



LP1013
RENAULT 6, AMI 8 - BUFFALO



LP1014
M. BENZ 608 COMPLETO



LP1016
FIAT 619 CAMION COMPLETO

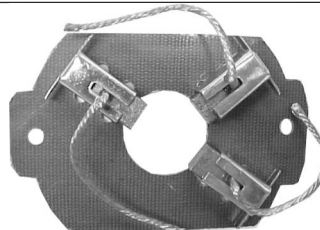



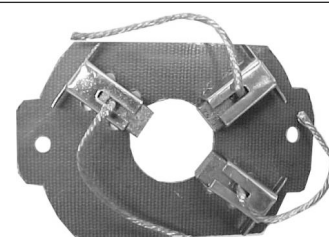







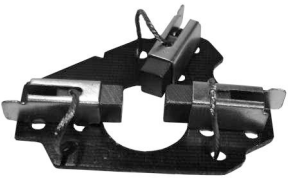
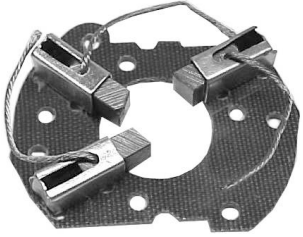
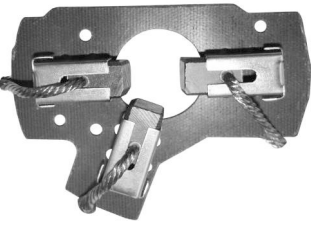
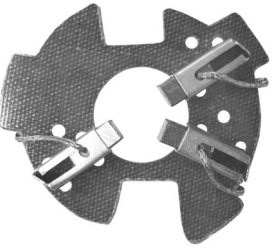
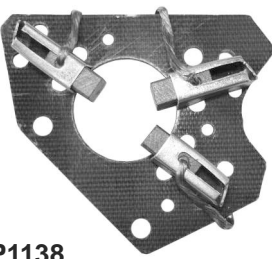

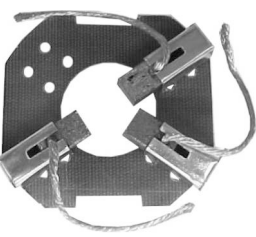

LP1017
RENAULT 12 - BUFFALO

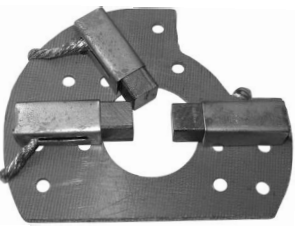
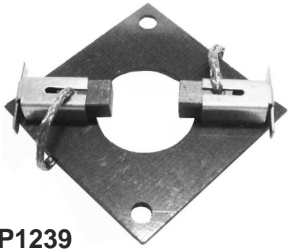
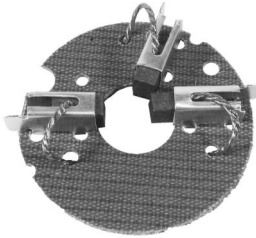

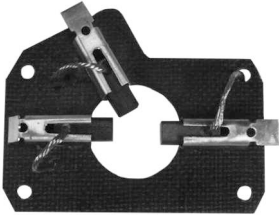
LP1018
PEUGEOT 504 - BUFFALO

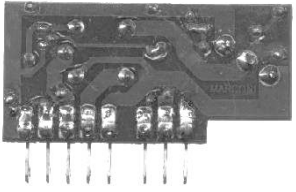
PORTAESCOBILLAS

 <p>LP1019 FORD FALCON DESDE 1982 - BRIEVA</p>	 <p>LP1020 R11/12/18, 504, GACEL - BUFFALO/BOSCH</p>	 <p>LP1021 FORD SIERRA COMPLETO</p>	 <p>LP1021A FIAT DUNA - BOSCH/ISACO</p>
 <p>LP1136 FORD F100 DESDE 1982 - BRIEVA</p>	 <p>LP1137 FIAT DUNA/UNO - MMA</p>	 <p>LP1138 FIAT 147 - ARNO</p>	 <p>LP1155 REGATTA, PEUGEOT 504/505</p>
 <p>LP1169 M.BENZ OH - BOSCH</p>	 <p>LP1179 FIAT DUCATO - M. MARELLI</p>	 <p>LP1187 CHEVROLET-M: D-20, MONZA, OPALA 5X5X11.5 - TIPO DELCO REMY</p>	 <p>LP1189 FIAT PALIO/SIENA</p>
 <p>LP1207 SCANIA 112 / 113</p>	 <p>LP1239 M. BENZ 608 MODELO VIEJO - BOSCH</p>	 <p>LP1254 PEUGEOT 306/307 - VALEO</p>	 <p>LP1255 MERIVA, PEUGEOT 306/307, ETC. - TRICO</p>
 <p>LP1288 FIAT147-TEG</p>	 <p>LP1292 FIATDUNA/PALIO-M.MARELLI</p>		
<p>VARIOS</p>			
 <p>LP1012 TRABAS DE CIERRE DE MOTOR</p>	 <p>LP1162 TEMPORIZADOR ELECTRONICO DUNA/UNO - ISAC</p>	 <p>LP1164 AUTOMATICO M. MARELLI</p>	 <p>LP1182 TOPE DE BOBINA FIAT DUNA/UNO</p>

VARIOS



LP1183
TOPE DE BOBINA M. BENZ -
ISACO



LP1184
RETEN DE ACERO FIAT,
M. BENZ, ETC.



LP1225
TOPE CONITO DE BOBINA DUNA

ENGRANAJES DE LUNETA



LP1072
DODGE 1500. ENGRANAJE
GRANDE: Z33/11 Ø21.5/7.8MM.
ENGRANAJE CHICO:
Z30/9 Ø17.3/6.6MM.



LP1112
ESCORT, REGATTA, DUNA.
ENGRANAJE: Z90 Ø64.8MM.



LP1141
FIAT DUNA ENGRANAJE:
Z90 Ø65.4MM.



LP1174
FORD FIESTA. ENGRANAJE:
Z105 Ø65MM.



LP1180
QUANTUM. ENGRANAJE:
Z56 Ø47.2MM.



LP1181
FORD KA. ENGRANAJE:
Z99 Ø61.5MM.



LP1203
VOLKSWAGEN CADY.
ENGRANAJE: Z62 Ø52.4MM.



LP1206
PARTNER. ENGRANAJE:
Z105 Ø64.6MM.



LP1215
PEUGEOT 306. ENGRANAJE:
Z100 Ø61.5MM.



LP1237
FIAT147. ENGRANAJE:
Z70 Ø58.5MM.



LP1306
FIATPALIOLINEANUEVA.
ENGRANAJE: Z105 Ø64.78MM.

ENGRANAJES DE LIMPIAPARABRISAS

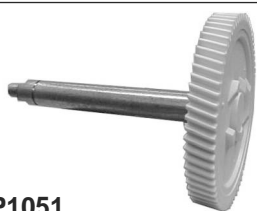

LP1051
CHEVROLET 400, CHEVY -
BRIEVA. ENGRANAJE:
Z70 Ø66MM. EJE: LARGO 91.3.
Ø11.3MM.



LP1052
M. BENZ 1114/1517 - BRIEVA.
ENGRANAJE: Z70 Ø65.8MM. EJE:
LARGO 36.8MM Ø11MM.



LP1053
FIAT 1600/125 - BRIEVA.
ENGRANAJE: Z70 Ø65.8MM. EJE:
LARGO 36.5MM. Ø11MM.



LP1054
FIAT 600/128 - BRIEVA.
ENGRANAJE: Z70 Ø66MM.
EJE: LARGO 41MM. Ø11MM.

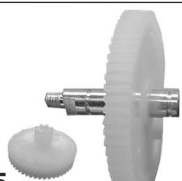

LP1055
JUEGO BUFFALO (TODOS).
ENGRANAJE GDE.: Z64, Ø50MM.
ENGRANAJE MED.: Z47 Ø28.3MM.
ENGRANAJE CHICO: Z7 Ø7MM.
EJE: LARGO 23.5MM. Ø8MM.



LP1056
AMI 8, RENAULT 6 - BUFFALO.
ENGRANAJE GRANDE: Z51
Ø30.8MM. ENGRANAJE CHICO:
Z8 Ø8MM.















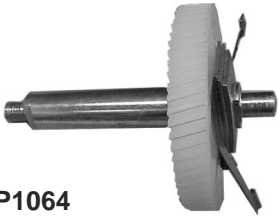









LP1057
M. BENZ 1112/1114. ENGRANAJE
GRANDE: Z49 Ø27MM.
ENGRANAJE CHICO: Z9 Ø7.5MM.

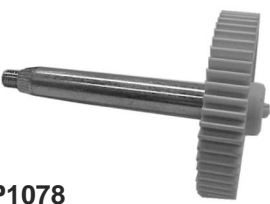
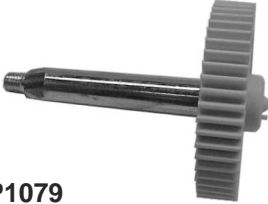

LP1058
DODGE CAMION, POLARA, FIAT -
EQUIPO TEG TODOS.
ENGRANAJE: Z51 Ø52.8MM. EJE:
LARGO 42.6MM. Ø10MM.

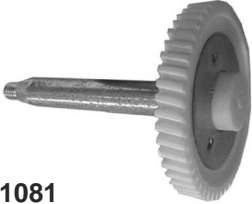

















ENGRANAJES DE LIMPIAPARABRISAS

 <p>LP1059 CHEVROLET 400 SUPER. ENGRANAJE: Z70 Ø65.5MM.</p>	 <p>LP1060 FIAT 1500 MODELO VIEJO. ENGRANAJE: Z68 Ø52.5MM.</p>	 <p>LP1061 FIAT 600/1100 MODELO VIEJO. ENGRANAJE: Z51 Ø52.4MM.</p>	 <p>LP1062 LINEA CHEYSLER, IKA, VALIANT, DODGE. ENGRANAJE: Z64</p>
 <p>LP1063 DODGE PICK UP. ENGRANAJE: Z64 Ø52.2MM. EJE: LARGO 52.3MM. Ø11MM.</p>	 <p>LP1064 FORD FALCON - EQUIPO INDICO MODELO VIEJO. ENGRANAJE: Z64 Ø52MM. EJE: LARGO 55.3MM Ø11MM.</p>	 <p>LP1065 M. BENZ 608 CHICO. ENGRANAJE: Z46 Ø31.3MM.</p>	 <p>LP1066 FIAT 619 MODELO VIEJO. ENGRANAJE: Z49 Ø64MM. EJE: LARGO 67.8MM Ø12.5MM.</p>
 <p>LP1067 PEUGEOT 504 - EQUIPO TEG. ENGRANAJE: Z51 Ø53MM. EJE: LARGO 40MM. Ø10MM.</p>	 <p>LP1068 FORD TAUNUS, SCANIA, GACEL, M. BENZ, RENAULT 18 - TEG. ENGRANAJE: Z49 Ø63.6MM. EJE: LARGO 47.1MM, Ø10MM.</p>	 <p>LP1068E SCANIA, M. BENZ - TEG. ENGRANAJE: Z49 Ø64.5MM. EJE: LARGO 49.5MM. Ø10MM. LARGO 47.1MM, Ø10MM.</p>	 <p>LP1069 PPEUGEOT 504 - EQUIPO BRIEVA. ENGRANAJE: Z70 Ø65.8MM. EJE: LARGO 37.5MM Ø11MM.</p>
 <p>LP1070 M. BENZ 608 EJE CORTO. ENGRANAJE: Z49 Ø64MM. EJE: LARGO 60.1MM. Ø10MM.</p>	 <p>LP1071 FORD FALCON - BRIEVA. ENGRANAJE: Z64 Ø52MM.</p>	 <p>LP1073 JUEGO ALBERA UNIVERSAL. ENGRANAJE GRANDE: Z34/9 Ø24/7.7MM. ENGRANAJE CHICO: Z33/9 Ø17.7/7.7MM.</p>	 <p>LP1075 JUEGO MITSUBA. ENGRANAJE GRANDE: Z30/8 Ø22/7.7MM. ENGRANAJE CHICO: Z34/8 Ø18.8/7.9MM.</p>
 <p>LP1074 M. BENZ 1112 (BRONCE GRANDE) - S.W.F. ENGRANAJE: Z72 Ø49.7MM. EJE: LARGO 37.4MM Ø8MM.</p>	 <p>LP1076 TAUNUS, GACEL, RENAULT 18, SCANIA. ENGRANAJE: Z49 Ø64.4MM. EJE: LARGO 47.8MM. Ø10MM.</p>	 <p>LP1077 JUEGO DE VW GACEL, RENAULT 18 - BUFFALO. ENGRANAJE GRANDE: Z29 Ø25.4MM. ENGRANAJE CHICO: Z15 Ø15.5MM.</p>	 <p>LP1078 FORD SIERRA - EQUIPO BUFFALO. ENGRANAJE: Z55 Ø50.3MM. EJE: LARGO 67.1MM Ø10MM.</p>
 <p>LP1079 PEUGEOT 505 - EQUIPO BUFFALO. ENGRANAJE: Z55 Ø50.3MM. EJE: LARGO 67.1MM. Ø10MM.</p>	 <p>LP1080 RENAULT 12 DE 1979 HASTA 1985 - BUFFALO. ENGRANAJE: Z50 Ø48MM. EJE: LARGO 48MM. Ø9MM.</p>	 <p>LP1081 RENAULT 6 DESDE 1979 HASTA 1984 - BUFFALO. ENGRANAJE: Z50 Ø48MM. EJE: LARGO 67.5MM. Ø9MM.</p>	 <p>LP1082 FIAT 147 - BRIEVA. ENGRANAJE: Z70 Ø66MM. EJE: LARGO 41.5MM Ø11MM.</p>

ENGRANAJES DE LIMPIAPARABRISAS

 <p>LP1083 CITROEN 3CV IES HASTA 1986. ENGRANAJE: Z70 Ø65.7MM. EJE: LARGO 38.3MM. Ø11MM.</p>	 <p>LP1084 CITROEN IES SUPER AMERICA DESDE 1987 - BRIEVA. ENGRANAJE: Z70 Ø65.7MM. EJE: LARGO 54.8MM Ø11MM.</p>	 <p>LP1085 RENAULT 12 MODELO NUEVO - BUFFALO. ENGRANAJE: Z57 Ø59.5MM. EJE: LARGO 63MM. Ø10MM.</p>	 <p>LP1086 PEUGEOT 504 MODELO NUEVO - BUFFALO. ENGRANAJE: Z57 Ø58.5MM. EJE: LARGO 38.3MM. Ø10MM.</p>
 <p>LP1087 M. BENZ 1112 PANTOGRAFO ENGRANAJE: Z57 Ø59.6MM. EJE: LARGO 43.3MM. Ø10MM.</p>	 <p>LP1089 PEUGEOT 504 - ALCE. ENGRANAJE: Z66 Ø60.6MM. EJE: LARGO 37.5MM. Ø11MM.</p>	 <p>LP1090 M. BENZ OH BRASIL. ENGRANAJE: Z49 Ø63.6MM. EJE: LARGO 73.7MM. Ø10MM.</p>	 <p>LP1091 FORD FALCON 1980/1981 - BRIEVA. ENGRANAJE: Z70 Ø66.8MM. EJE: LARGO 53.9MM. Ø11MM.</p>
 <p>LP1092 CITROEN AMI 8 GRANDE DE METAL. ENGRANAJE: Z60 Ø45.8MM. EJE: LARGO 21.5MM. Ø9MM.</p>	 <p>LP1093 RENAULT 6 GRANDE DE METAL. ENGRANAJE: Z60 Ø45.7MM. EJE: LARGO 36.6MM. Ø9MM.</p>	 <p>LP1094 PEUGEOT 505 - TEG. ENGRANAJE: Z88 Ø66.2MM. EJE: LARGO 52MM. Ø10MM.</p>	 <p>LP1095 FIAT DUNA/UNO - BOSCH. ENGRANAJE: Z90 Ø65MM.</p>
 <p>LP1096 FORD F100 DESDE 1981 - BRIEVA. ENGRANAJE: Z49 Ø64.3MM. EJE: LARGO 79.7MM. Ø11MM.</p>	 <p>LP1097 FIAT - TEG M. MARELLI. ENGRANAJE: Z68 Ø52.3MM. EJE: LARGO 43MM. Ø10MM.</p>	 <p>LP1098 CHEVY 1974 - BRIEVA. ENGRANAJE: Z70 Ø66.7MM. EJE: LARGO 89.2MM. Ø11MM.</p>	 <p>LP1099 MERCEDES BENZ - BOSCH. ENGRANAJE: Z49 Ø64.1MM. EJE: LARGO 63,8MM. Ø11MM.</p>
 <p>LP1100 RENAULT 11 - BUFFALO. ENGRANAJE: Z55 Ø50.3MM. EJE: LARGO 58.1MM. Ø10MM.</p>	 <p>LP1102 FORD TAUNUS 1983/1984, SENDA - BUFFALO. ENGRANAJE: Z55 Ø50.3MM. EJE: LARGO 58.1MM. Ø10MM.</p>	 <p>LP1105 RENAULT 18, VW, GACEL - BUFFALO. ENGRANAJE: Z55 Ø50.3MM. EJE: LARGO 57.8MM. Ø10MM.</p>	 <p>LP1106 FIAT - INDICO. ENGRANAJE: Z54 Ø55.7MM. EJE: LARGO 34.7MM. Ø11MM.</p>
 <p>LP1107 RENAULT 11/12/18, TAUNUS, FIAT, DESDE 1986 - BUFFALO. ENGRANAJE: Z55 Ø50.3MM. EJE: LARGO 58.1MM. Ø10MM.</p>	 <p>LP1109 FIAT REGATTA - M. MARELLI. ENGRANAJE: Z58 Ø61.4MM. EJE: LARGO 47.5MM. Ø10MM.</p>	 <p>LP1110 FORD FALCON 85 (ROSCA GRUESA) - TEG. ENGRANAJE: Z49 Ø64MM. EJE: LARGO 65.7MM. Ø11MM.</p>	 <p>LP1110E FORD FALCON 85 REFORZADO (ROSCA GRUESA) - TEG. ENGRANAJE: Z49 Ø64.4MM. EJE: LARGO 71.8MM. Ø11MM.</p>

ENGRANAJES DE LIMPIAPARABRISAS

 <p>LP1111 FORD 14000 - BOSCH. ENGRANAJE: Z63 Ø65.2MM. EJE: LARGO 80.2MM. Ø10MM.</p>	 <p>LP1113 FIAT REGATTA - TEG. ENGRANAJE: Z88 Ø66MM. EJE: LARGO 52MM. Ø10MM.</p>	 <p>LP1114 FIAT DUNA/UNO - M. MARELLI. ENGRANAJE: Z55 Ø57.6MM</p>	 <p>LP1115 RENAULT 21 MODELO 1989, TRAFIC - BUFFALO, VALEO. ENGRANAJE: Z55 Ø50.5MM. EJE: LARGO 55.4MM. Ø10MM.</p>
 <p>LP1116 FORD FALCON 1982 A 1985 - BRIEVA. ENGRANAJE: Z49 Ø64MM. EJE: LARGO 63.1MM. Ø11MM.</p>	 <p>LP1117 CHEVROLET PICK UP C10 - BRIEVA. ENGRANAJE: Z49 Ø64MM. EJE: LARGO 91MM. Ø11MM.</p>	 <p>LP1118 FORD ESCORT/SIERRA - BUFFALO. ENGRANAJE: Z55 Ø50.4MM. EJE: LARGO 68MM. Ø10MM.</p>	 <p>LP1119 FORD FALCON DESDE 1982 CON DOS FRESADOS. ENGRANAJE: Z49 Ø64.2MM. EJE: LARGO 45MM. Ø10MM.</p>
 <p>LP1120 CHEVROLET MONZA - BOSCH. ENGRANAJE: Z54 Ø57.6MM. EJE: LARGO 53.2MM. Ø11MM.</p>	 <p>LP1121 PEUGEOT 504/505, GACEL - TEG. ENGRANAJE: Z88 Ø66.3MM. EJE: LARGO 51.8MM. Ø10MM.</p>	 <p>LP1122 FORD GALAXY/ESCORT - BOSCH. ENGRANAJE: Z88 Ø65.2MM. EJE: LARGO 44.7MM. Ø10MM.</p>	 <p>LP1123 FIAT REGATTA - BRIEVA. ENGRANAJE: Z58 Ø61.3MM. EJE: LARGO 47.5MM. Ø10MM.</p>
 <p>LP1124 M. BENZ OH EJE PASANTE. ENGRANAJE: Z49 Ø64MM. EJE: LARGO 58MM. Ø10MM.</p>	 <p>LP1125 VALIANT DE SOTO. ENGRANAJE: Z69 Ø55.5MM.</p>	 <p>LP1126 SCANIA - BOSCH. ENGRANAJE: Z49 Ø64.5MM. EJE: LARGO 61MM. Ø10MM.</p>	 <p>LP1134 FORD CARGO, SCANIA. ENGRANAJE: Z63 Ø65.3MM. EJE: LARGO 53.5MM. Ø10MM.</p>
 <p>LP1139 CHEVROLET OPEL K180. ENGRANAJE: Z70 Ø65MM. EJE: LARGO 55.6 Ø10MM.</p>	 <p>LP1142 FIAT 619 - BOSCH. ENGRANAJE: Z72 Ø77.4MM. EJE: LARGO 68MM. Ø10MM.</p>	 <p>LP1143 DACIA. ENGRANAJE: Z55 Ø56.5MM. EJE: LARGO 53.5MM. Ø10MM.</p>	 <p>LP1145 FIAT 147 - BOSCH. ENGRANAJE: Z54 Ø57.5MM. EJE: LARGO 44.4MM. Ø10MM.</p>
 <p>LP1146 FORD 1000, CHEVETTE - BOSCH. ENGRANAJE: Z54 Ø57.4MM. EJE: LARGO 44.3MM. Ø10MM.</p>	 <p>LP1147 CHEVETTE. ENGRANAJE: Z54 Ø57.4MM. EJE: LARGO 56MM. Ø10MM.</p>	 <p>LP1148 FORD ESCORT - BOSCH. ENGRANAJE: Z88 Ø65MM. EJE: LARGO 44.3MM. Ø10MM.</p>	 <p>LP1154 FIAT DUNA/UNO GRUESO - BOSCH. ENGRANAJE: Z55 Ø65.3MM.</p>

ENGRANAJES DE LIMPIAPARABRISAS



LP1156
FIAT DUNA/UNO - EQUIPO MMA.
ENGRANAJE: Z48 Ø50.5MM.



LP1157
DODGE POLARA. ENGRANAJE:
Z69 Ø83MM.

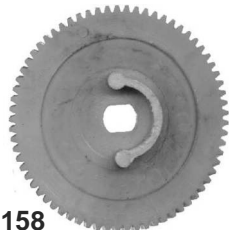

LP1158
DODGE CAMION, POLARA.
ENGRANAJE: Z69 Ø82.6MM.

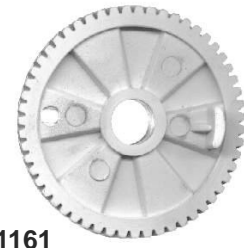

LP1161
FIAT DUNA CON LEVA DE CORTE
- M. MARELLI. ENGRANAJE: Z55



LP1163E
ISACO MODELO NUEVO
REFORZADO. ENGRANAJE: Z50
Ø64.3MM. EJE: LARGO 55.9MM.



LP1166
TRAFIC, M. BENZ, BOSCH.
ENGRANAJE: Z63 Ø64.8MM. EJE:
LARGO 61.3MM. Ø10MM.



LP1167
M. BENZ 180 - BOSCH.
ENGRANAJE: Z63 Ø65.2MM.
EJE: LARGO 64.9MM. Ø10MM.



LP1168
M. BENZ SERIE L - TIPO BOSCH.
ENGRANAJE: Z63 Ø65.3MM. EJE:
LARGO 46.4MM. Ø10MM.



LP1170
FORD FAIRLANE. ENGRANAJE
GRANDE: Z30 Ø34.5MM.
ENGRANAJE CHICO: Z11 Ø14.3MM



LP1171
GOL, GACEL, PEUGEOT 504/505
GIRO IZQUIERDO - EQUIPO MMA.
ENGRANAJE: Z88 Ø66.3MM. EJE:
LARGO 51.3MM. Ø10MM.



LP1172
FIAT 147 - M. MARELLI.
ENGRANAJE: Z54 Ø57.4MM.
EJE: LARGO 47.8MM. Ø10MM.



LP1173
FIAT DUCATO - M. MARELLI.
ENGRANAJE: Z63 Ø65.5MM.
EJE: LARGO 50.1MM. Ø10MM.



LP1175
FIAT PALIO. ENGRANAJE: Z82
Ø47.7MM.



LP1177
FIAT IVECO 619 GIRO IZQUIERDO
- BOSCH. ENGRANAJE: Z72
Ø76.8MM. EJE: LARGO 68.6MM.
Ø10MM.



LP1178
M. BENZ CHICO 24V. - BRIEVA.
ENGRANAJE: Z58 Ø61.5MM.
EJE: LARGO 47.3MM. Ø10MM.



LP1185
SCANIA 112/113. ENGRANAJE:
Z46 Ø76.9MM. EJE: LARGO
66.3MM. Ø14MM.



LP1188
FIAT PALIO/SIENA. ENGRANAJE:
Z55 Ø57.6MM. EJE: LARGO
43.7MM. Ø10MM.

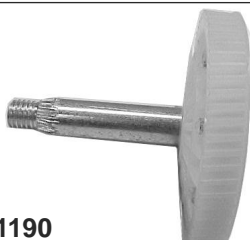

LP1190
CHEVROLET CORSA.
ENGRANAJE: Z61 Ø59.4MM.
EJE: LARGO 43.7MM. Ø10MM.



LP1194
SIAM DI TELLA. ENGRANAJE:
Z85 Ø69.2MM.



LP1195
TATA. ENGRANAJE: Z34 Ø70MM.



LP1196
PEUGEOT PARTNER, BERLINGO.
ENGRANAJE: Z55 Ø57.5MM.
EJE: LARGO 51.5MM. Ø10MM.



LP1197
FORD TRANSIT. ENGRANAJE:
Z55 Ø57.4MM. EJE: LARGO
47.7MM. Ø10MM.



LP1198
CITROEN C15. ENGRANAJE:
Z54 Ø57.6MM. EJE:
LARGO 45.3MM. Ø10MM.



LP1199
RENAULT CLIO - BOSCH.
ENGRANAJE: Z55 Ø57.5MM. EJE:
LARGO 48MM. Ø10MM.

ENGRANAJES DE LIMPIAPARABRISAS

LP1200

VW GOL.
ENGRANAJE: Z88 Ø65.3MM.
EJE: LARGO 62.5MM. Ø10MM.

LP1201

FORD FIESTA. ENGRANAJE:
Z63 Ø65.2MM. EJE:
LARGO 46.9MM. Ø10MM.

LP1202

VW POLO. ENGRANAJE: Z55
Ø57.4MM. EJE: LARGO 53.1MM.
Ø10MM.

LP1204

FORD KA. ENGRANAJE: Z88
Ø65MM. EJE: LARGO 49MM.
Ø10MM.

LP1205

PEUGEOT 206. ENGRANAJE:
Z55 Ø57.3MM. EJE: LARGO 45MM.
Ø10MM.

LP1208

M. BENZ MODELO NUEVO CON
ESTRIAS - BRIEVA. ENGRANAJE:
Z58 Ø61.5MM. EJE:
LARGO 64.4MM. Ø10MM.

LP1209

PEUGEOT 505 - ARNO.
ENGRANAJE: Z49 Ø63.8MM.
EJE: LARGO 50.7MM. Ø10MM.

LP1210

M. BENZ CON MOLETEADO -
DOGA ESPAÑOL. ENGRANAJE:
Z50 Ø66.1MM. EJE: LARGO
67.6MM. Ø12MM.

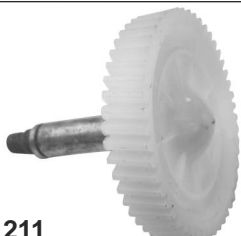
LP1211

M. BENZ CON ROSCA - DOGA
ESPAÑOL. ENGRANAJE: Z50
Ø66.3MM. EJE: LARGO 57.7MM.

LP1212

CRYSLER NEON. ENGRANAJE:
Z55 Ø61.3MM. EJE:
LARGO 51MM. Ø12MM.

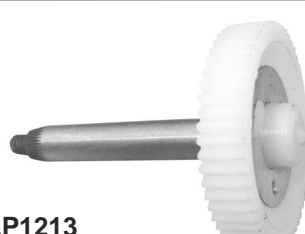
LP1213

FIAT 147 - BUFFALO.
ENGRANAJE: Z55 Ø50.5MM.
EJE: LARGO 66.6MM. Ø10MM.

LP1216

FORD EJE INTERMEDIO -
BRIEVA. ENGRANAJE: Z40
Ø64MM. EJE: LARGO 75MM.
Ø11MM.

LP1217

FIAT 147 - TEG. ENGRANAJE: Z51
Ø53.5MM. EJE: LARGO 42.7MM.
Ø10MM.

LP1218

PEUGEOT 405 - M. MARELLI.
ENGRANAJE: Z55 Ø57.6MM.
EJE: LARGO 45.6MM. Ø10MM.

LP1219

CHEVROLET ASTRA.
ENGRANAJE: Z55 Ø57.6MM.
EJE: LARGO 48.5MM. Ø11MM.

LP1220

TOYOTA. ENGRANAJE: Z100
Ø62.7MM. EJE: LARGO 44.8MM.
Ø9MM.

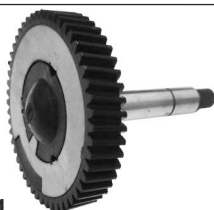
LP1221

CON AUTOMATICO DE BRONCE
Y MOLETEADO - TIPO DOGA.
ENGRANAJE: Z50 Ø65.5MM.
EJE: LARGO 69.2MM. Ø12MM.

LP1222

MODELO NUEVO - ISACO.
ENGRANAJE: Z49 Ø63.2MM.
EJE: LARGO 56MM. Ø11MM.

LP1223

M. BENZ 709 AÑO 1995.
ENGRANAJE: Z110 Ø81MM.
EJE: LARGO 61.1MM. Ø12MM.

LP1227

M. BENZ 608 MODELO VIEJO.
ENGRANAJE: Z54 Ø70MM.
EJE: LARGO 59MM. Ø10MM.

LP1228

ISUZU MODELO NUEVO.
ENGRANAJE: Z54 Ø69.3MM.
EJE: LARGO 63.1MM. Ø10MM.

LP1229

FIAT DUCATO - M. MARELLI.
ENGRANAJE: Z55 Ø57.5MM.
EJE: LARGO 52.1MM. Ø10MM.











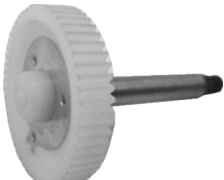
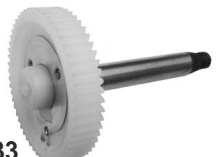
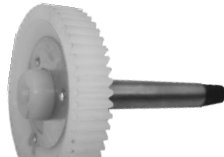

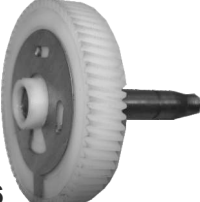







LP1230

EJE LARGO - ISACO.
ENGRANAJE: Z50 Ø64MM. EJE:
LARGO 66.8MM. Ø11MM.

LP1231

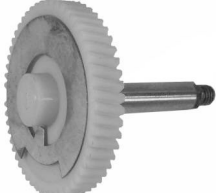
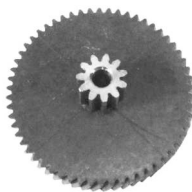
M. BENZ CON CONTACTO DE
BRONCE. ENGRANAJE: Z50
Ø65.8MM. EJE: LARGO 59MM.
Ø12MM.

ENGRANAJES DE LIMPIAPARABRISAS

 <p>LP1232 MODELO NUEVO CON RANURA - BUFFALO. ENGRANAJE: Z55 Ø50.4MM. EJE: LARGO 68.2MM. Ø10MM.</p>	 <p>LP1233 PEUGEOT 306/307 MODELO NUEVO CON ROSCA DE 8MM. Y FRESADO - BUFFALO. ENGRANAJE: Z55 Ø50.5MM. EJE: LARGO 69.3MM. Ø10MM.</p>	 <p>LP1234 M. BENZ MOLETEADO - BUFFALO. ENGRANAJE: Z55 Ø49.8MM. EJE: LARGO 69.1MM. Ø10MM.</p>	 <p>LP1235 M. BENZ EJE MOLETEADO - ISACO. ENGRANAJE: Z49 Ø63.4MM. EJE: LARGO 67MM. Ø11MM.</p>
 <p>LP1236 VW FOX. ENGRANAJE: Z69 Ø57.7MM. EJE: LARGO 53.3MM Ø10MM.</p>	 <p>LP1238 MERIVA - TRICO. ENGRANAJE: Z61 Ø59.5MM. EJE: LARGO 44.5MM. Ø10MM.</p>	 <p>LP1240 PEUGEOT 306 - TRICO. ENGRANAJE: Z61 Ø59.6MM. EJE: LARGO 49.7MM. Ø10MM.</p>	 <p>LP1242 FIAT EUROCARGO. ENGRANAJE: Z110 Ø81MM. EJE: LARGO 56.4MM. Ø12MM.</p>
 <p>LP1243 CHRYSLER CARAVAN. ENGRANAJE: Z110 Ø81.2MM. EJE: LARGO 43.6MM. Ø12MM.</p>	 <p>LP1245 PEUGEOT 307 - TRICO. ENGRANAJE: Z61 Ø59.2MM. EJE: LARGO 49.8MM. Ø10MM.</p>	 <p>LP1248 CHEVROLET LUMINA/S10/ BLAZER. ENGRANAJE: Z88 Ø64.1MM. EJE: LARGO 55.6MM. Ø12MM.</p>	 <p>LP1249 ECOSPORT - VALEO. ENGRANAJE: Z53 Ø52MM. EJE: LARGO 48.8MM. Ø10MM.</p>
 <p>LP1250 RENAULT SCENIC - BOSCH. ENGRANAJE: Z63 Ø65.3MM. EJE: LARGO 47.4MM. Ø10MM.</p>	 <p>LP1251 MERIVA, ROVER AÑO 1996. ENGRANAJE: Z61 Ø59.5MM. EJE: LARGO 44.1MM. Ø10MM.</p>	 <p>LP1252 MAZDA 626 AÑO 1980. ENGRANAJE: Z100 Ø62.5MM. EJE: LARGO 48.4MM. Ø9MM.</p>	 <p>LP1253 FORD ECONO. ENGRANAJE: Z61 Ø59.5MM. EJE: LARGO 49.8MM. Ø10MM.</p>
 <p>LP1257 KIA. ENGRANAJE: Z65 Ø57.5MM. EJE: LARGO 49MM. Ø9.95MM.</p>	 <p>LP1258 UNIVERSAL - BRIEVA. ENGRANAJE: Z60 Ø43.4MM. EJE: LARGO 27.7MM. Ø10MM.</p>	 <p>LP1260 FORD RANGER MODELO NUEVO. ENGRANAJE: Z61 Ø59.4MM. EJE: LARGO 64.3MM. Ø10MM.</p>	 <p>LP1261 CHEVROLET MONZA EJE LARGO. ENGRANAJE: Z54 Ø57.4MM. EJE: LARGO 59.2MM. Ø11MM.</p>
 <p>LP1262 UNIMOG. ENGRANAJE GRANDE: Z58 Ø31.8MM. ENGRANAJE CHICO: Z11 Ø8MM.</p>	 <p>LP1263 PEUGEOT 505 - DUCELLIER. ENGRANAJE: Z44 Ø63.5MM. EJE: LARGO 58MM. Ø10MM.</p>	 <p>LP1264 CHEVROLET S10 - TRICO. ENGRANAJE: Z61 Ø59.4MM. EJE: LARGO 57.4MM Ø10MM.</p>	 <p>LP1265 CARAVAN, FIESTA. ENGRANAJE: Z63 Ø65.6MM. EJE: LARGO 50.4MM Ø12MM.</p>

ENGRANAJES DE LIMPIAPARABRISAS

LP1266

BLAZER MODELO 98.
ENGRANAJE: Z78 Ø64.1MM.
EJE: LARGO 56.4MM. Ø11MM.

LP1267

DAEWO. ENGRANAJE: Z60
Ø63.3MM. EJE: LARGO 51.5MM.
Ø10MM.

LP1268

M. BENZ 280 MODELO 99.
ENGRANAJE: Z63 Ø65.7MM.
EJE: LARGO 51.8MM. Ø12MM.

LP1269

M. BENZ. ENGRANAJE: Z59
Ø61.3MM. EJE: LARGO 57.5MM.
Ø12MM.

LP1270

MERIVA GIRO INVERSO - TRICO.
ENGRANAJE: Z61 Ø59.3MM.
EJE: LARGO 44.3MM. Ø10MM.

LP1271

FIAT TIPO - M. MARELLI.
ENGRANAJE: Z55 Ø57.6MM.
EJE: LARGO 52MM. Ø10MM.

LP1272

PALIO 2011 - BOSCH.
ENGRANAJE: Z105 Ø64.4MM.

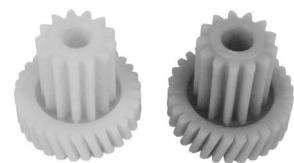
LP1273

JUEGO DE FORD ECOSPORT.
ENGRANAJE: Z30/13 Ø25.7/15MM.

LP1274

M. BENZ - BOSCH. ENGRANAJE:
Z46 Ø77.8MM. EJE:
LARGO 74.2MM. Ø10MM.

LP1275

MEGANE-VALEO.ENGRANAJE:
Z53Ø56.5MM.EJE:LARGO61MM.
Ø12MM.

LP1276

TIPOMARCOPOLO-VALEO.
ENGRANAJE:Z53Ø51.7MM.
EJE:LARGO72MM.Ø12MM.

LP1277

FORDCARGO.ENGRANAJE:
Z59Ø70.7MM.EJE:LARGO61.8MM.
Ø11.8MM.

LP1278

MERCEDES BENZ SUPERTRANS
MOTOR CHINO. ENGRANAJE:
Z63 Ø64.8MM. EJE: LARGO57MM.
Ø9.95MM.

LP1279

ASTRA 2008 - BOSCH.
ENGRANAJE: Z69 Ø57.5MM.
EJE: LARGO 47MM. Ø9.95MM.

LP1280

FORD F100/RANGER MODELO
NUEVO EJE CORTO.
ENGRANAJE: Z100 Ø63MM.
EJE: LARGO 36.3MM. Ø12MM.

LP1281

FORD F100/RANGER MODELO
NUEVO EJE LARGO. ENGRANAJE:
Z100 Ø63.2MM. EJE: LARGO:
53MM. Ø12MM.

LP1282

DODGE JOURNEY. ENGRANAJE:
Z68 Ø63.4MM. EJE: LARGO 47MM.
Ø10MM.

LP1283

CHEVROLET AVEO.
ENGRANAJE: Z66 Ø54.6MM.
EJE: LARGO 46MM. Ø10MM.

LP1284

VW AMAROK. ENGRANAJE: Z63
Ø64.7MM. EJE: LARGO: 46MM.
Ø10MM.

LP1285

ENGRANAJE PARA TECHO
PEUGEOT 206/307 - MITSUBA.
ENGRANAJE: Z57 Ø52MM.

LP1287

FIAT PUNTO. ENGRANAJE: Z63
Ø64,8MM. EJE: LARGO: 49,5MM.
Ø10MM.

LP1289

FORD KA LINEA NUEVA.
ENGRANAJE: Z88 Ø64,8MM.
EJE: LARGO: 50.7MM. Ø10MM.

LP1290

RENAULT MEGANE 2.
ENGRANAJE: Z63 Ø64,6MM.
EJE: LARGO: 51MM. Ø12MM.

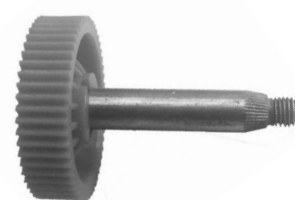
LP1291

VALEO EJE INTERMEDIO.
ENGRANAJE: Z53 Ø51,5MM.
EJE: LARGO: 57,5MM. Ø11,95MM.

ENGRANAJES DE LIMPIAPARABRISAS

 <p>LP1293 FORDFIESTAGRANDE-VALEO. ENGRANAJE:Z53Ø51,8MM.EJE: LARGO47MM.Ø9,95MM.</p>	 <p>LP1294 JUEGOFORDFIESTA-VALEO ENGRANAJES:Z30/13 Ø25,6/14,9MM.</p>	 <p>LP1295 BRIEVA. ENGRANAJE: Z58 Ø61, 1MM. EJE: LARGO 55,5MM. Ø9,95MM.</p>	 <p>LP1296 CITROEN C4 - TRICO. ENGRANAJE: Z61 Ø58.57MM. EJE: LARGO 49.65MM. Ø10MM.</p>
 <p>LP1297 CAMIÓN SAPO-TRICO. ENGRANAJE:Z61Ø58.77MM. EJE:LARGO51MM.Ø12MM.</p>	 <p>LP1298 JUEGO CHEVROLETS10/C10. ENGRANAJE:Z3/13Ø27.5/15.9MM.</p>	 <p>LP1301 JUEGO COLECTIVO-KINGMATIC. ENGRANAJES:Z29/15Ø40.39/21MM</p>	 <p>LP1303 TOYOTA HILUX MODELO NUEVO. ENGRANAJE:Z64Ø59.5MM.EJE: LARGO48.10MM.Ø10MM.</p>
 <p>LP1304 TRAFIC-BUFFALO.ENGRANAJE: Z55Ø50.49MM.EJE:LARGO59MM. Ø10MM.</p>	 <p>LP1305 DAEWOMATIZ.ENGRANAJE: Z60Ø62.57MM.EJE: LARGO50.56MM.Ø10MM.</p>	 <p>LP1299 ASTRA2000.ENGRANAJE:Z55Ø57 MM.EJE:LARGO41.20MM.Ø10MM.</p>	 <p>LP1300 VOLVO,SCANIA.ENGRANAJE: Z81Ø83MM.EJE:LARGO57.5MM. Ø12MM.</p>
 <p>LP1307 FIAT CUBO.ENGRANAJE:Z67 Ø64.65MM.EJE:LARGO51.15MM. Ø12MM.</p>	 <p>LP1308 PEUGEOT MASTER-VALEO. ENGRANAJES:Z31/13Ø25.45/15MM.</p>	 <p>LP1309 CHEVROLET SILVERADO. ENGRANAJE:Z96Ø76.10EJE: LARGO64.6MM.Ø11MM.</p>	 <p>LP1310 VWAVEO/BORA/VENTO-BOSCH MEXICO.ENGRANAJE: Z75Ø55MM. ROSCA:8MM.EJE:LARGO45.2MM. Ø10MM.</p>
 <p>LP1311 M.BENZEJERECTOTIPO MARCO POLO.ENGRANAJE: Z49Ø64.1MM.EJE:LARGO56MM. Ø11MM.</p>	 <p>LP1312 RENAULT KOLEO.ENGRANAJE: Z63Ø65.60MM.EJE:LARGO48MM. Ø10MM.</p>		

HERRAMIENTAS



V1690
EXPANSOR GRANDE DE MASAS POLARES CON CAMPOS



V1770
EXPANSOR CHICO DE MASAS POLARES CON CAMPOS



V1781
PRENSA PARA TORNILLOS MASAS POLAR



V1781/1
PUNTA PHILLIPS PARA PRENSA



V1781/2
PUNTA PLANA PARA PRENSA



V1781/3
PUNTA PALA PLANA REFORZADA
PARA PRENSA







V1782
LLAVE EXTRACTORA DE POLEA



V1783
LLAVE EXTRACTORA DE POLEA

VARIOS

 <p>V1048 ARO BOCINA FALCON HASTA 1972 (CANT.1)</p>	 <p>V1063 ADAPTADORES DE LAMPARA BIODO (CANT. 2)</p>	 <p>V1180 VAINAS PLASTICAS PARA TERMINAL PALA (CANT. 50) V1180/25 IDEM (CANT. 25)</p>	 <p>V1185 CLIP DE TAPA DE DISTRIBUIDOR (CANT. 2)</p>
 <p>V1190 RESORTE UNIVERSAL DE ACELERADOR 355MM.</p>		 <p>V1191 RESORTE UNIVERSAL 150MM.</p>	
 <p>V1192 RESORTE UNIVERSAL MEDIANO CON DOS SOPORTES LARGOS 160MM.</p>	 <p>V1193 RESORTE UNIVERSAL MEDIANO</p>	 <p>V1194 RESORTE UNIVERSAL CORTO CON 1 SOPORTE LARGO100MM.</p>	
 <p>VA1000 MANCHON DE ACOPLA PARA BOMBA HIBRAULICA</p>	 <p>VD1001 CUERPO SUPERIOR DISTRIBUIDOR TIPO INDIEL CON BUJE (54404346)</p>	 <p>VD1002 CUERPO SUPERIOR DISTRIBUIDOR TIPO INDIEL CON BUJE (35412064)</p>	 <p>VP1101 TORNILLOS PARKER SURTIDOS (CANT.100)</p>
 <p>VP1102 TORNILLOSPARKER10X1/2MM. (CANT. 50)</p>	 <p>VP1102/7 TORNILLOS PARKER 7X1/2MM. (CANT. 25)</p>	 <p>VP1102/8 TORNILLOS PARKER 8X5/8MM. (CANT. 25)</p>	 <p>VP1102/10 TORNILLOS PARKER 10X1/2MM. (CANT. 25)</p>
 <p>VR0117 REGISTROS DE FARO CHEVROLET COMPLETOS (CANT. 2)</p>	 <p>VR0118 REGISTROS DE FARO FORD LARGO (CANT. 2)</p>	 <p>VR0119 REGISTROS DE FARO FORD LARGO (CANT. 2)</p>	 <p>VT1130 TORNILLOS SURTIDOS CON TUERCA (CANT.100)</p>

VARIOS

 <p>VT1163 TUERCAS RAPIDAS PARA TORNILLOS PARKER (CANT. 20)</p>	 <p>VT1163C TUERCAS RAPIDAS CHICAS Nº 7 (CANT. 20)</p>	 <p>VT1163C/6 TUERCAS RAPIDAS CHICAS Nº 6 (CANT. 20)</p>	 <p>VT1163M TUERCAS RAPIDAS MEDIANAS Nº 8 (CANT. 20)</p>
--	--	---	--

 <p>VT1163M/10 TUERCAS RAPIDAS MEDIANAS Nº 10 (CANT. 20)</p>	 <p>VT1163G TUERCAS RAPIDAS GRANDES Nº 12 (CANT. 20)</p>	 <p>VT1208 TERMINALES PUNTERA CABLE 70MM. - (CANT. 5)</p>	
--	--	--	--

GRAMPAS DE CHASIS

 <p>G4581 GRAMPAS DE CHASIS CHICAS (CANT. 20)</p>	 <p>G4582 GRAMPAS DE CHASIS MEDIANAS (CANT. 20)</p>	 <p>G4583 GRAMPAS DE CHASIS GRANDES (CANT. 20)</p>	
---	---	---	--

CAPUCHONES DE OPTICA

 <p>G4086 JUEGO CAPUCHON DE OPTICA UNIVERSAL (CANT. 2)</p>	 <p>G4091 JUEGO CAPUCHON DE OPTICA PEUGEOT 504 MODELO VIEJO (CANT. 2)</p>	 <p>G4092 JUEGO CAPUCHON DE OPTICA DODGE 1500 (CANT. 2)</p>	 <p>G4093 JUEGO CAPUCHON DE OPTICA R11 (CANT.2)</p>
 <p>G4094 JUEGO CAPUCHON DE OPTICA PEGUEOT (CANT. 2)</p>	 <p>G4095 JUEGO CAPUCHON DE OPTICA R18 (CANT. 2)</p>	 <p>G4096 JUEGO CAPUCHON DE OPTICA DUCATO, BOXER (CANT. 2)</p>	 <p>G4097 JUEGO CAPUCHON DE OPTICA GACEL/SENDA (CANT. 2)</p>

CAPUCHONES DE OPTICA



G4098
JUEGO CAPUCHON DE OPTICA
FIAT UNO/DUNA (CANT. 2)



G4099
JUEGO CAPUCHON DE OPTICA
RENAULT 19 (CANT. 2)

PASACABLES DE GOMA



G4011
PASACABLES GOMA SURTIDAS
(CANT. 20)



G4011/1
GOMAS PASACABLES
5.5X7MM. - (CANT. 10)



G4011/2
GOMAS PASACABLES
10X12MM. - (CANT. 10)



G4011/3
GOMAS PASACABLES
11X16MM. - (CANT. 10)



G4011/4
GOMAS PASACABLES
10X20MM. - (CANT. 10)



G4011/5
GOMAS PASACABLES
12X20MM. - (CANT. 10)



G4011/6
GOMAS PASACABLES
17X20MM. - (CANT. 10)



G4011/7
GOMAS PASACABLES
12X23MM. - (CANT. 10)



G4011/8
GOMAS PASACABLES
19X26MM. - (CANT. 10)



G4011/9
GOMAS PASACABLE
22X32MM. - (CANT. 10)



G4020
GOMAS PARA PORTALAMPARA
DE OPTICA (CANT. 2)



G4021
GOMAS PARA PORTALAMPARA
DE OPTICA (CANT. 20)



G4022
JUEGO GOMAS GRANDE
PARA PORTALAMPARA DE
OPTICA (CANT. 2)



G4023
GOMAS PARA PORTALAMPARA
DE OPTICA GRANDE (CANT. 20)